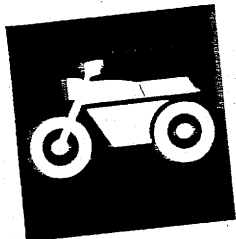


**YAMAHA**

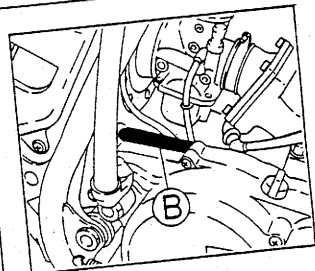
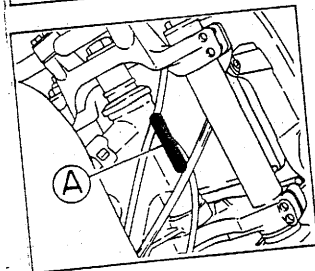


**PARTS  
CATALOGUE**

**WR250ZE (4DC3) '93**

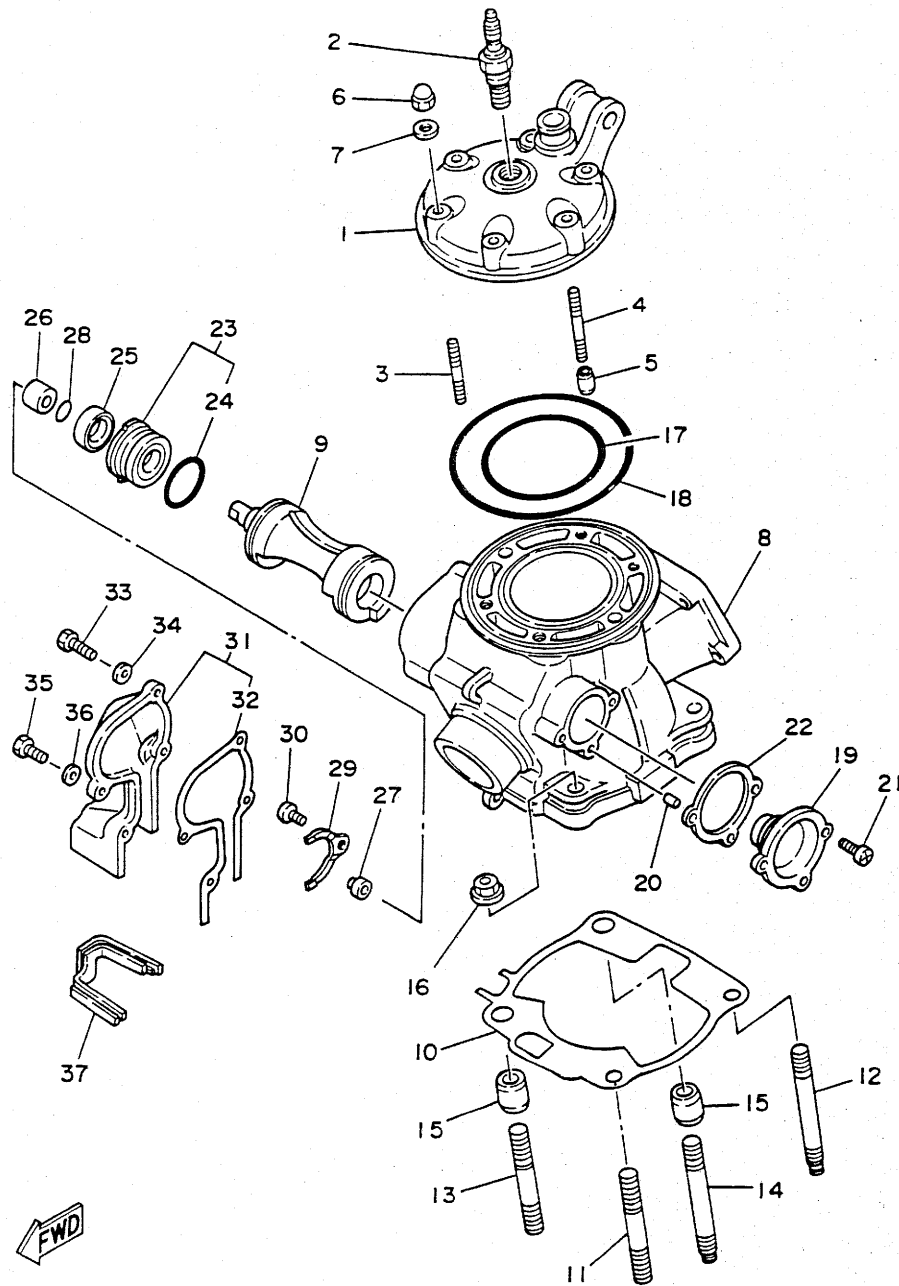
Initial Serial No. and Color Code

(A) Frame Serial No.	4DC-006101 and following
(B) Engine Serial No.	4DC-006101 and following



Color Code	Color Name	Abbreviate
0206	PURPLISH WHITE SOLID 1	PWS1

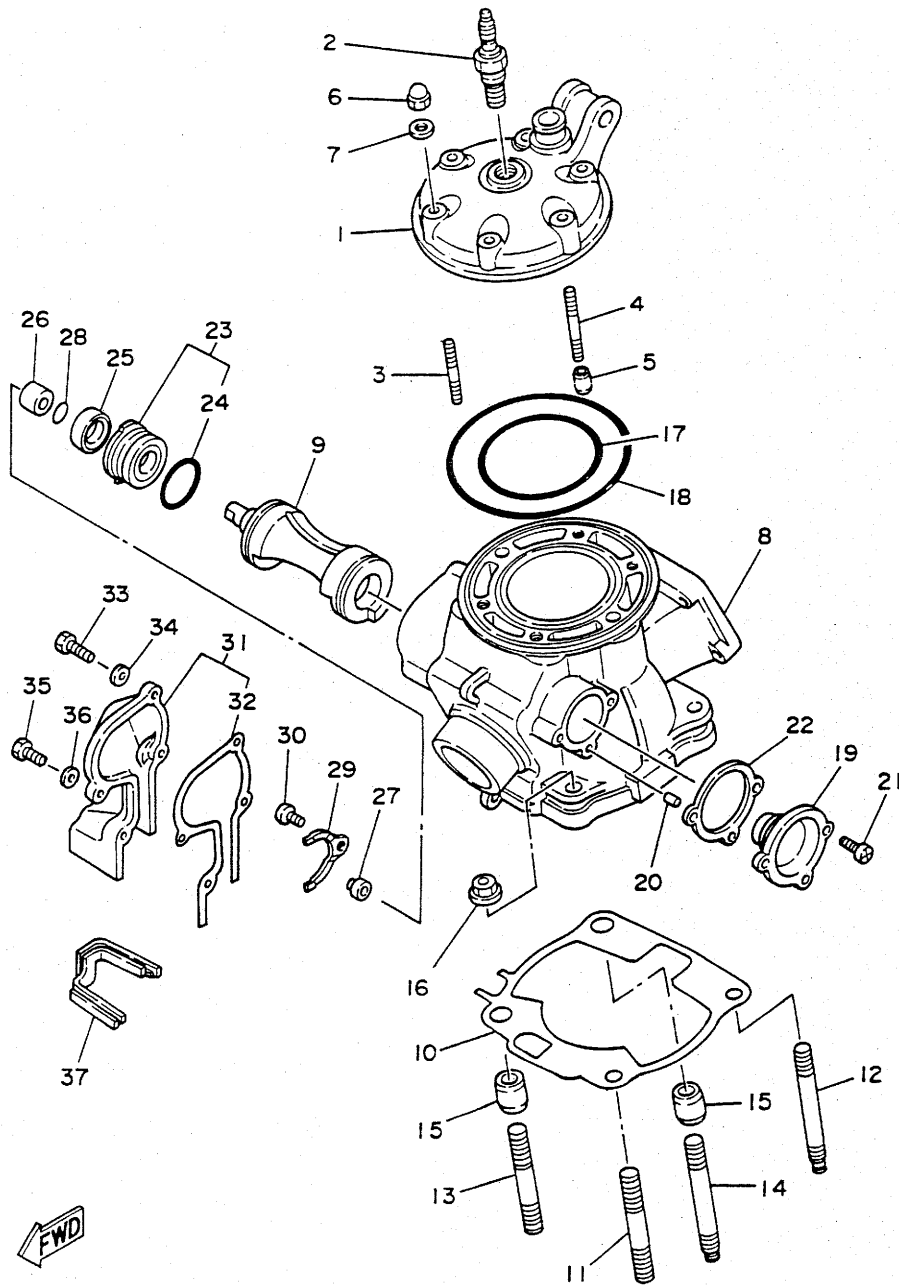
FIG. 1 CYLINDER HEAD



REF. NO.	PART NO.	DESCRIPTION	Q'TY	REMARKS
1	4DA-11111-01	HEAD, cylinder 1	1	
2	BR8EG	PLUG, spark	1	
3	90116-08394	BOLT, stud	4	
4	90116-08392	BOLT, stud	2	
5	99510-10114	PIN, dowel	2	
6	90176-08026	NUT, crown	6	
7	90201-08087	WASHER, plate	6	
8	4DA-11311-00	CYLINDER 1	1	
9	4DA-1131A-00	VALVE 1	1	
10	2VM-11351-10	GASKET, cylinder	1	
11	90116-10314	BOLT, stud	1	
12	90116-10547	BOLT, stud	1	
13	90116-10314	BOLT, stud	1	
14	90116-10547	BOLT, stud	1	
15	99530-14016	PIN, dowel	2	
16	95701-10500	NUT, flange	4	
17	93210-77363	O-RING	1	
18	93211-11770	O-RING	1	
19	3JE-W1132-00	HOLDER 1	1	
20	93604-08071	PIN, dowel	1	
21	98501-05012	SCREW, pan head	2	
22	3JE-1131N-10	GASKET, holder	1	
23	5X4-Y113F-10	HOLDER 2 ASSY	1	
24	93210-270A8	O-RING	1	
25	93104-16074	OIL SEAL	1	
26	90387-102W0	COLLAR	1	

FWD

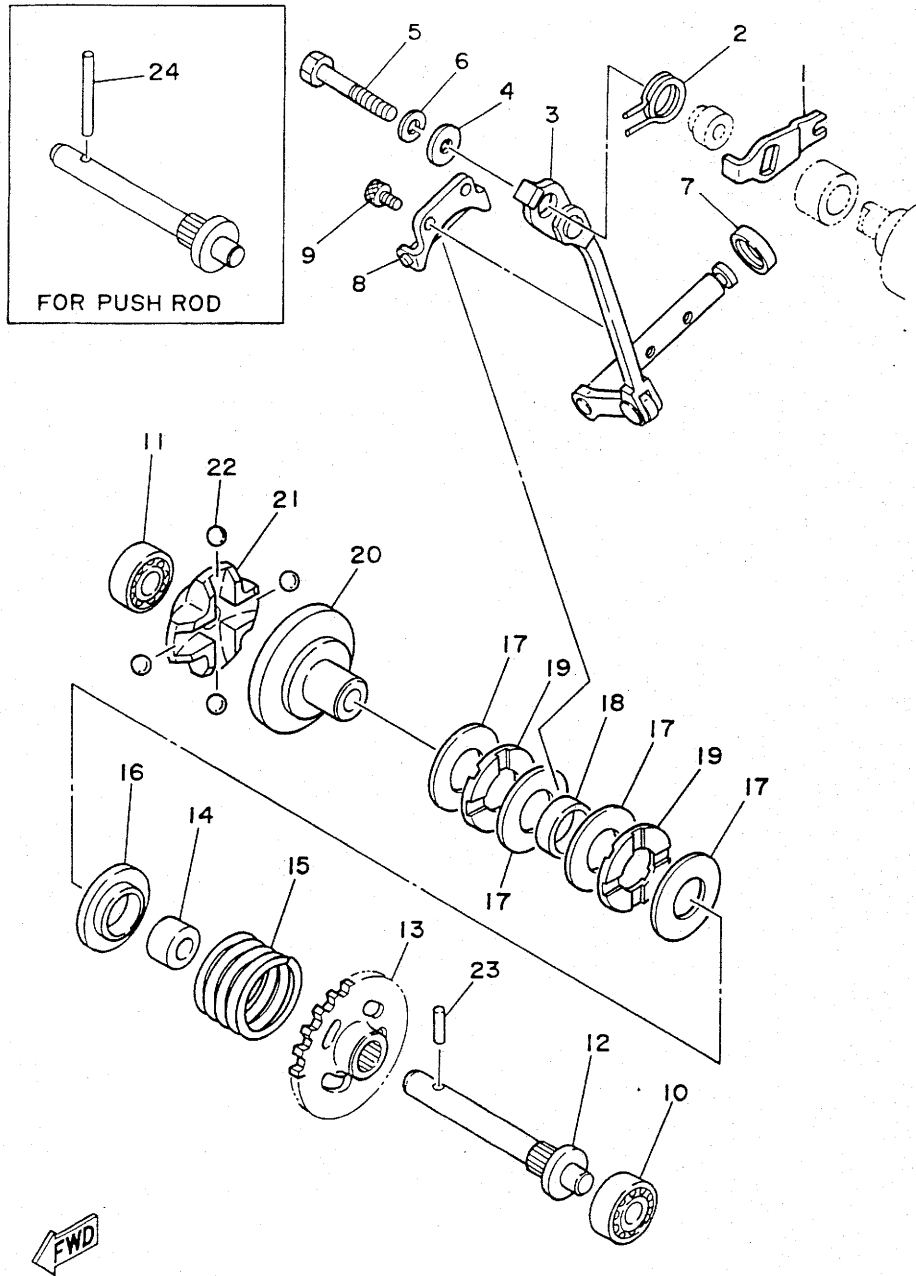
FIG. 1 CYLINDER HEAD



REF. NO.	PART NO.	DESCRIPTION	Q'TY	REMARKS
27	3JE-11937-00	BOSS, lever	1	
28	93210-09192	O-RING	1	
29	1LX-11915-00	PLATE, thrust 1	1	
30	98506-05008	SCREW, pan head	1	
31	3SP-11992-10	HOUSING 2	1	
32	3SP-11993-10	.GASKET	1	
33	97021-05020	BOLT	2	
34	92901-05600	WASHER, plate	2	
35	97001-05016	BOLT	2	
36	92901-05600	WASHER, plate	2	
37	2VM-11995-00	SEAL, housing	1	

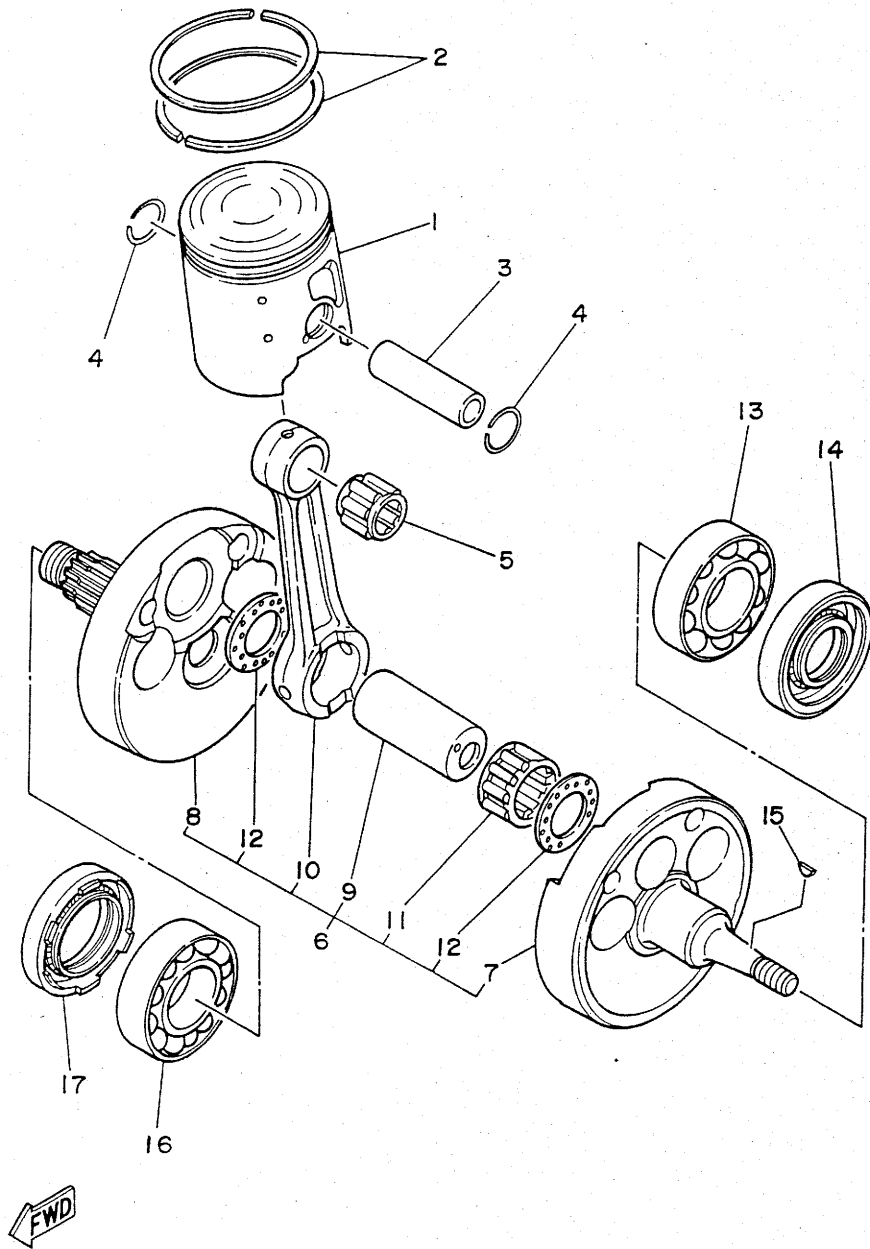
FWD

FIG. 2 GOVERNOR



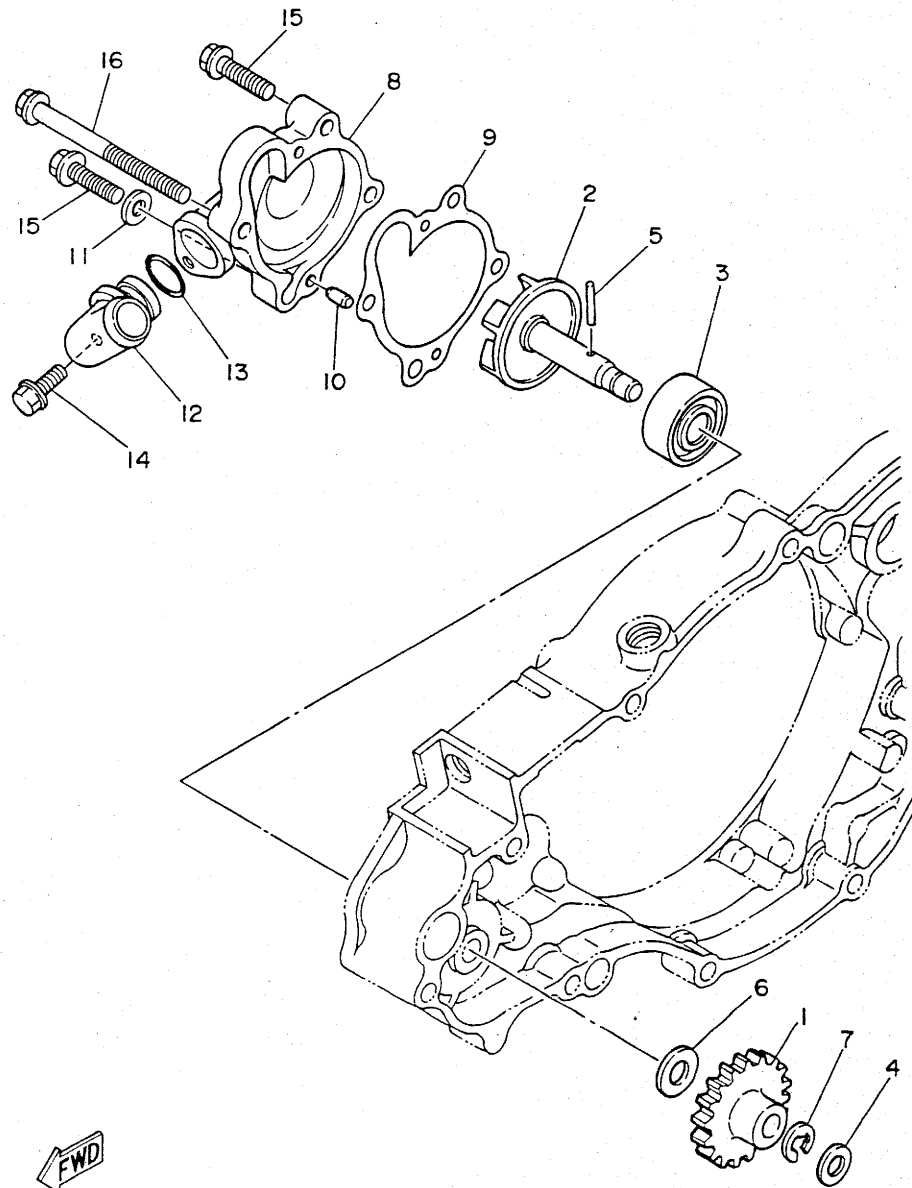
REF. NO.	PART NO.	DESCRIPTION	Q'TY	REMARKS
1	3JE-11931-00	LEVER	1	
2	90508-14783	SPRING, torsion	1	
3	3SP-11990-00	PUSH ROD ASSY	1	
4	90201-057H5	WASHER, plate	1	
5	97021-05030	BOLT	1	
6	92990-05100	WASHER, spring	1	
7	93104-08040	OIL SEAL	1	
8	3JE-11922-00	FORK, governor	1	
9	91316-04006	BOLT	2	
10	93300-60814	BEARING (608M4ML01)	1	NMB
11	93300-60814	BEARING (608M4ML01)	1	NMB
12	5X4-11921-02	SHAFT, governor	1	
13	24X-11953-01	GEAR, governor	1	
14	90560-08213	SPACER	1	
15	90501-240F4	SPRING, compression	1	
16	5X4-11952-00	PLATE	1	
17	90201-154E9	WASHER, plate	4	
18	90387-152F2	COLLAR	1	
19	93340-21505	BEARING, thrust	2	
20	5X5-11912-01	RETAINER, weight	1	
21	5X5-11911-01	RETAINER	1	
22	93521-64032	BALL	4	
23	93603-14179	PIN, dowel	1	
24	93604-29184	PIN, dowel	1	AP FOR PUSH ROD

FIG. 3 CRANKSHAFT. PISTON



REF. NO.	PART NO.	DESCRIPTION	Q'TY	REMARKS
1	4DA-11631-00-A0	PISTON (STD)	1	UR RED
	4DA-11631-00-B0	PISTON (STD)	1	UR ORANGE
	4DA-11631-00-C0	PISTON (STD)	1	UR GREEN
	4DA-11631-00-D0	PISTON (STD)	1	UR PURPLE
2	4DA-11601-00	PISTON RING SET (STD)	1	
3	2VM-11633-01	PIN, piston	1	
4	93450-19052	CIRCLIP	2	
5	93310-418E9	BEARING, cylindrical	1	
6	3XK-11400-01	CRANKSHAFT ASSY	1	
7	3XK-11412-01	.CRANK 1	1	
8	3XK-11422-01	.CRANK 2	1	
9	3JE-11681-01	.PIN, crank 1	1	
10	5X5-11651-02	.ROD, connecting	1	
11	93310-425T1	.BEARING, cylindrical	1	
12	90209-25085	.WASHER	2	
13	93306-37802	BEARING	1	
14	93102-22363	OIL SEAL	1	
15	90280-03017	KEY, woodruff	1	
16	93306-37802	BEARING	1	
17	93103-40091	OIL SEAL	1	

FIG. 4 WATER PUMP

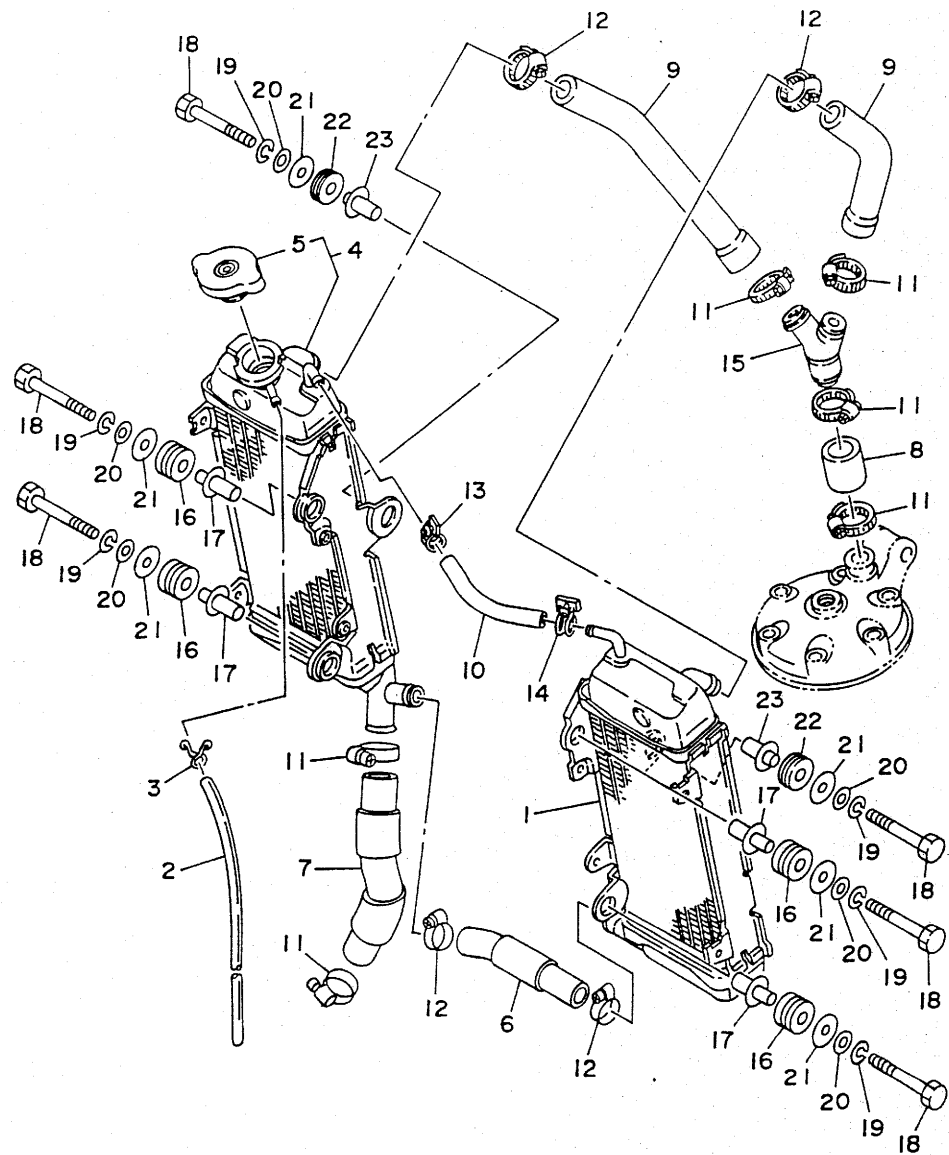


REF. NO.	PART NO.	DESCRIPTION	Q'TY	REMARKS
1	2VM-12459-00	GEAR, impeller shaft	1	
2	2VM-12450-00	IMPELLER SHAFT ASSY	1	
3	93103-10147	OIL SEAL	1	
4	90201-08759	WASHER, plate	1	
5	93603-22028	PIN, dowel	1	
6	90201-08784	WASHER, plate	1	
7	99009-06600	CIRCLIP	1	
8	3SP-12422-00	COVER, housing	1	
9	2VM-12428-00	GASKET, housing cover 2	1	
10	93604-10011	PIN, dowel	2	
11	90430-06166	GASKET	1	
12	10V-12469-01	JOINT 1	1	
13	93210-16275	O-RING	1	
14	95023-06025	BOLT	1	
15	95023-06025	BOLT	3	
16	95021-06080	BOLT, flange	1	

FWD

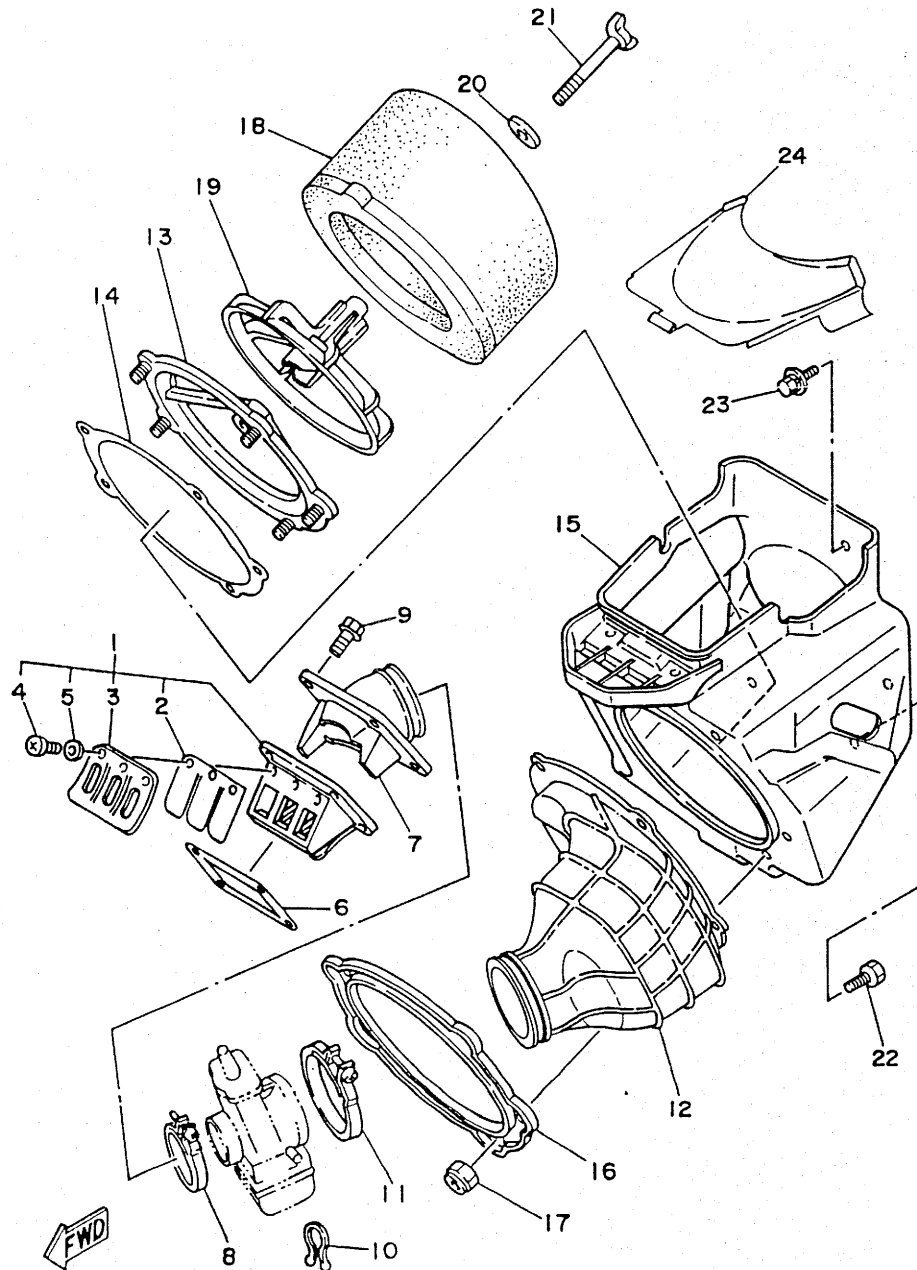
FIG. 5 RADIATOR. HOSE

REF. NO.	PART NO.	DESCRIPTION	Q'TY	REMARKS
1	3SP-1240A-01	RADIATOR ASSY	1	
2	90446-09013	HOSE	1	
3	90467-09006	CLIP	1	
4	4DC-12460-00	RADIATOR ASSY 2	1	
5	22W-12462-00	.CAP, radiator	1	
6	4DC-12482-00	PIPE 2	1	
7	4DC-12483-00	PIPE 3	1	
8	3SP-12485-00	PIPE 5	1	
9	4DC-12476-00	PIPE 6	2	
10	4DC-1248A-00	PIPE 8	1	
11	90450-28014	HOSE CLAMP ASSY	6	
12	90450-22052	HOSE CLAMP ASSY	4	
13	90450-15041	HOSE CLAMP ASSY	1	
14	90450-17036	HOSE CLAMP ASSY	1	
15	24X-12469-00	JOINT 1	1	
16	90480-15528	GROMMET	4	
17	90560-07382	SPACER	4	
18	97021-06050	BOLT	6	
19	92990-06100	WASHER, spring	6	
20	92901-06600	WASHER, plate	6	
21	90201-06570	WASHER, plate	6	
22	90480-18276	GROMMET	2	
23	90560-06383	SPACER	2	



FWD

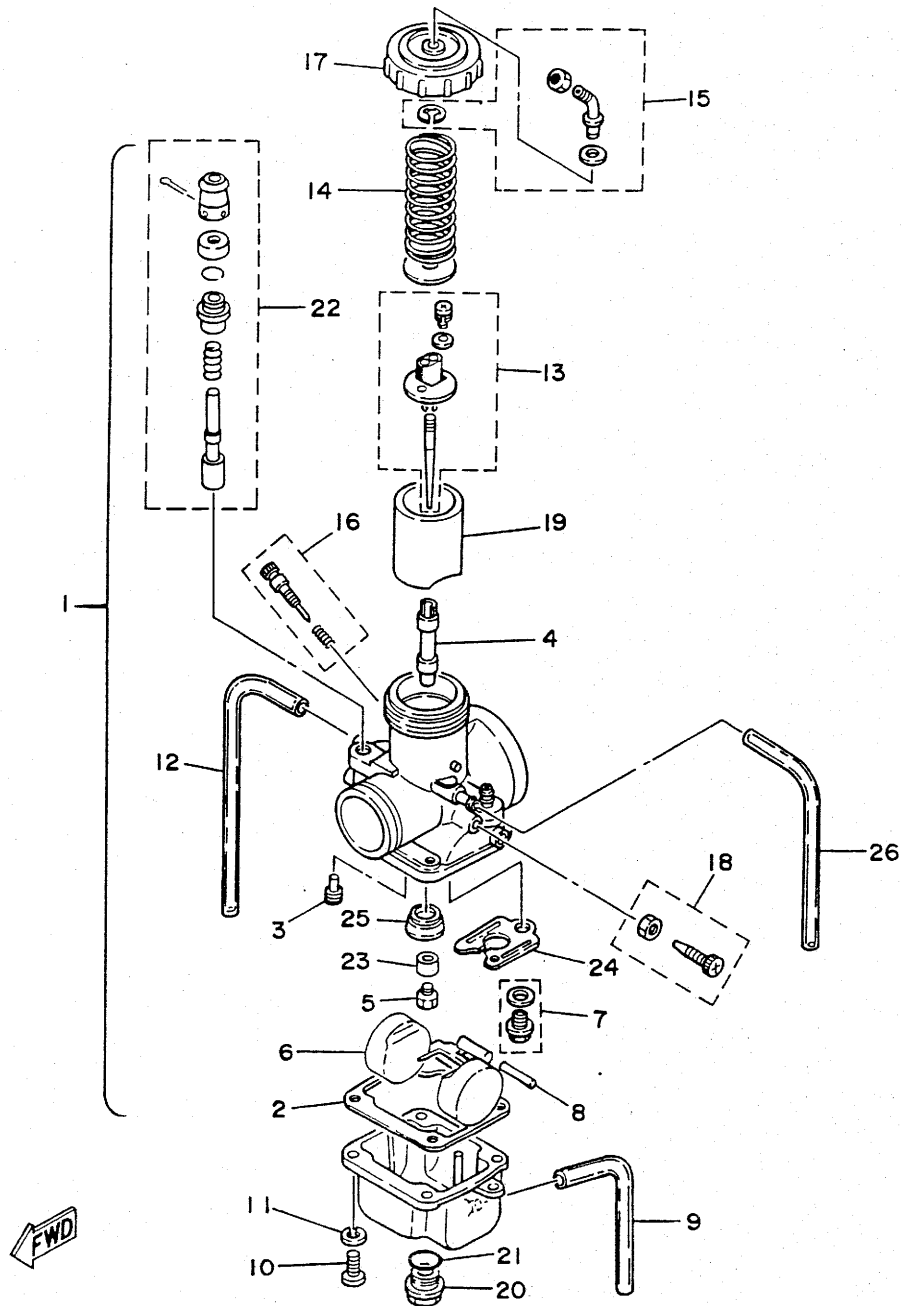
FIG. 6 INTAKE



REF. NO.	PART NO.	DESCRIPTION	Q'TY	REMARKS
1	4DC-13610-00	REED VALVE ASSY	1	
2	3SP-13613-00	.REED, valve	2	
3	4DA-13616-00	.STOPPER, reed valve	2	
4	98580-03008	.SCREW, pan head	6	
5	92990-03100	.WASHER, spring	6	
6	2K7-13621-10	GASKET, valve seat	1	
7	4DC-13565-00	JOINT, carburetor	1	
8	90460-51109	CLAMP, hose	1	
9	95023-06020	BOLT	4	
10	90464-16039	CLAMP	1	
11	90460-68230	CLAMP, hose	1	
12	4AA-14453-00	JOINT, air cleaner 1	1	
13	3JD-14459-00	HOLDER, guide	1	
14	3JD-14462-00	SEAL	1	
15	3XJ-W1441-01	AIR CLEANER CASE COMP.	1	
16	3JD-14477-00	PLATE	1	
17	95601-05100	NUT, u	5	
18	3JD-14451-00	ELEMENT, air cleaner	1	
19	3JD-14458-00	GUIDE	1	
20	90209-06096	WASHER	1	
21	90122-06035	BOLT, wing	1	
22	95023-06010	BOLT	1	
23	90119-06185	BOLT, with washer	3	
24	3XJ-1441A-00	COVER, cleaner case 1	1	AP FOR AIR CLEANER COVER



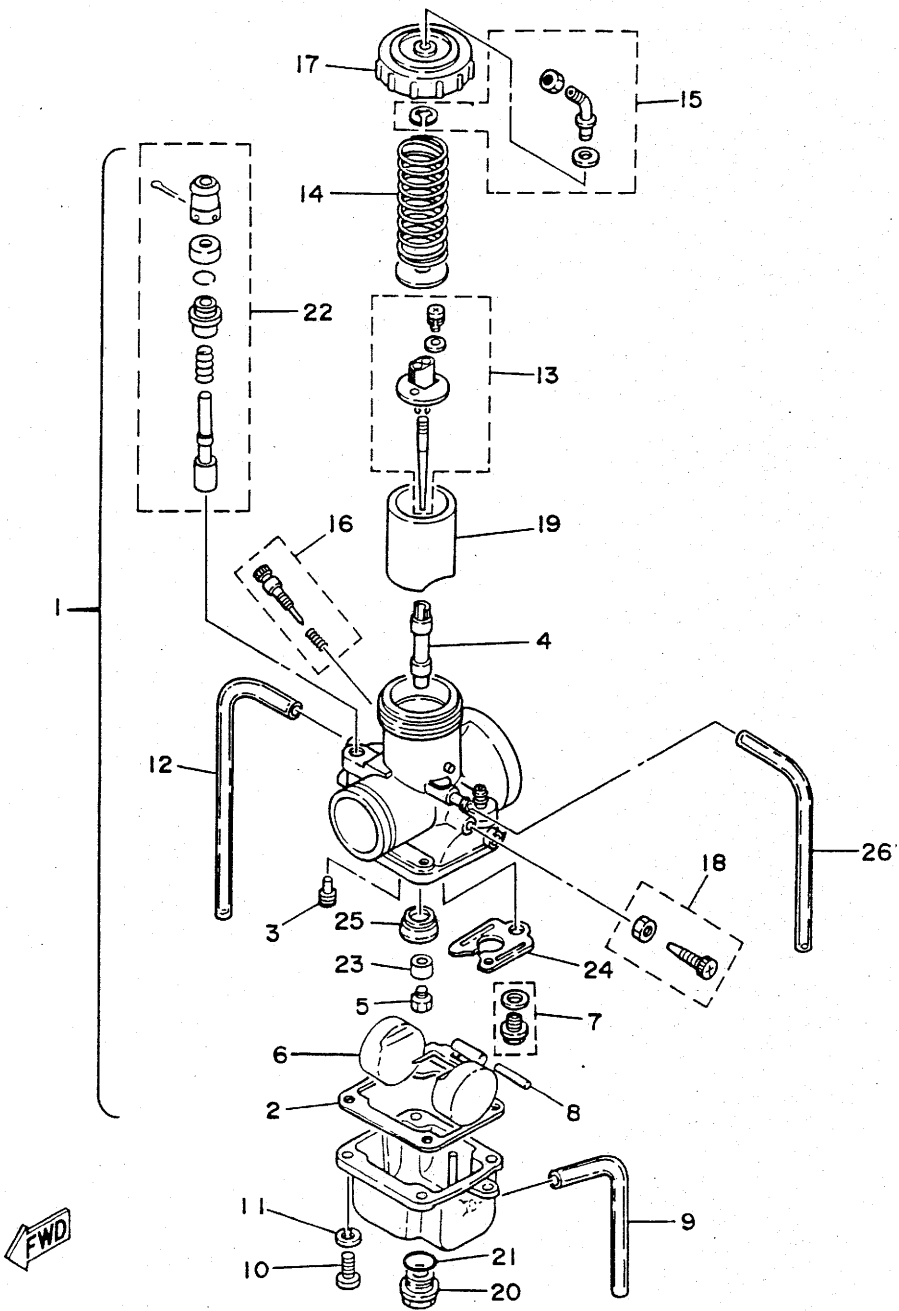
FIG. 7 CARBURETOR



REF. NO.	PART NO.	DESCRIPTION	Q'TY	REMARKS
1	4DC-14101-00	CARBURETOR ASSY 1	1	
2	363-14184-00	.GASKET, float chamber	1	
3	193-14142-40-A1	.JET, pilot (# 40)	1	STD
	193-14142-35	.JET, pilot (#35)	1	AP
	193-14142-45-A1	.JET, pilot (# 45)	1	AP
4	510-14141-R2	.NOZZLE, main	1	STD
	510-14141-R0	.NOZZLE, main	1	AP
	510-14141-R4	.NOZZLE, main	1	AP
5	137-14143-72	.JET, main (#360)	1	STD
	137-14143-70	.JET, main (#350)	1	AP
	137-14143-74	.JET, main (#370)	1	AP
6	2N7-14185-00	.FLOAT	1	
7	23X-14107-35	.NEEDLE VALVE SET	1	
8	537-14186-00	.PIN, float	1	
9	510-14197-00	.PIPE	1	
10	98501-05016	.SCREW, pan head	4	
11	92901-05100	.WASHER, spring	4	
12	2HH-14197-00	.PIPE	1	
13	23X-1490J-00	.NEEDLE SET	1	
14	431-14131-00	.SPRING, throttle valve	1	
15	23X-14106-00	.CABLE ADJUST SCREW SET	1	
16	23X-14104-00	.AIR SCREW SET	1	
17	5Y9-14158-00	.TOP, mixing chamber	1	
18	23X-14103-00	.THROTTLE SCREW SET	1	
19	2X8-14112-40	.VALVE, throttle 1	1	STD
	2X8-14112-35	.VALVE, throttle 1	1	AP
	2X8-14112-45	.VALVE, throttle 1	1	AP
20	510-14115-00	.PLUG, screw	1	

FIG. 7 CARBURETOR

REF. NO.	PART NO.	DESCRIPTION	Q'TY	REMARKS
21	558-14147-00	.O-RING	1	
22	24X-1410A-00	.STARTER SET	1	
23	5X5-14153-00	.WASHER, main jet	1	
24	3R4-14146-00	.PLATE	1	
25	509-14145-00	.SETTER, needle jet	1	
26	3SP-14149-00	.PIPE	1	



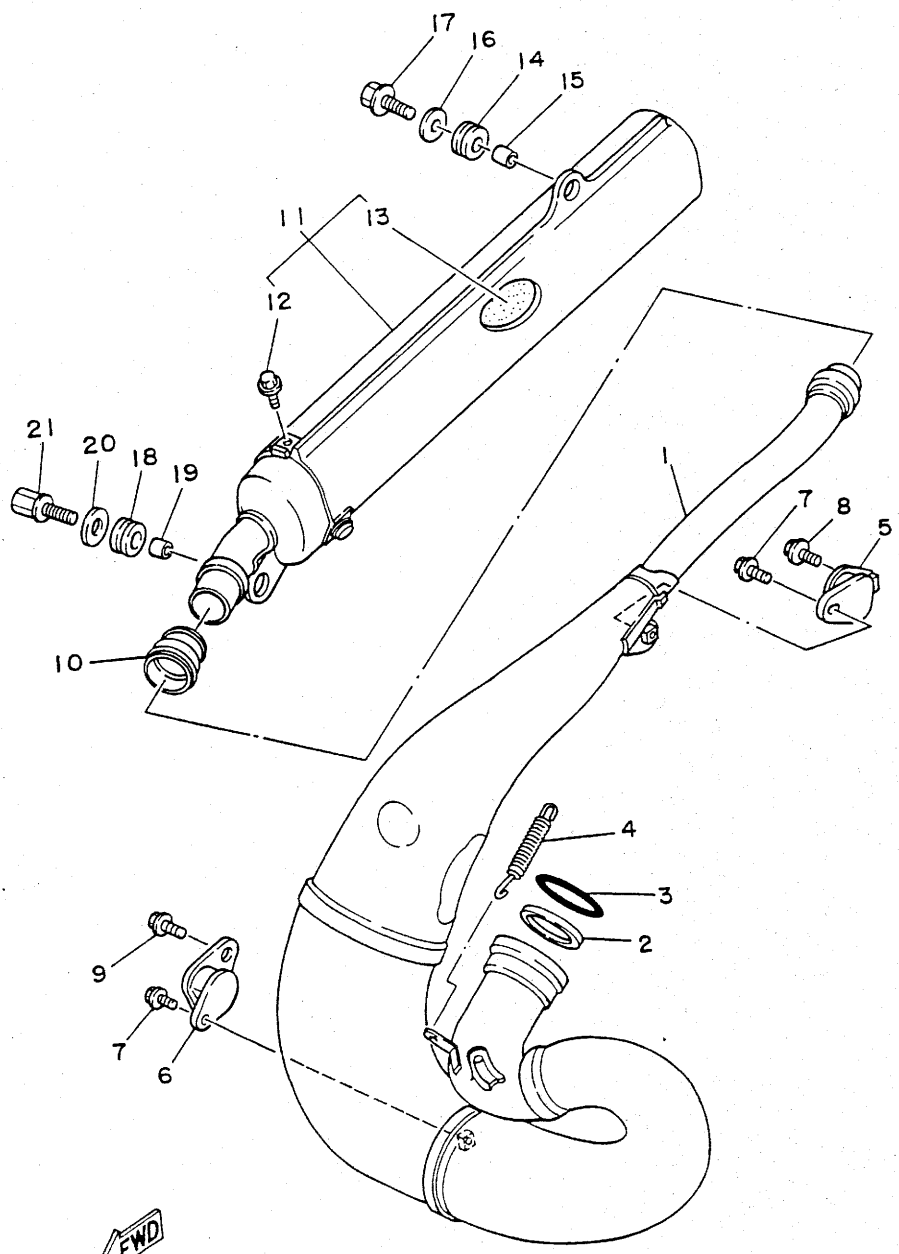
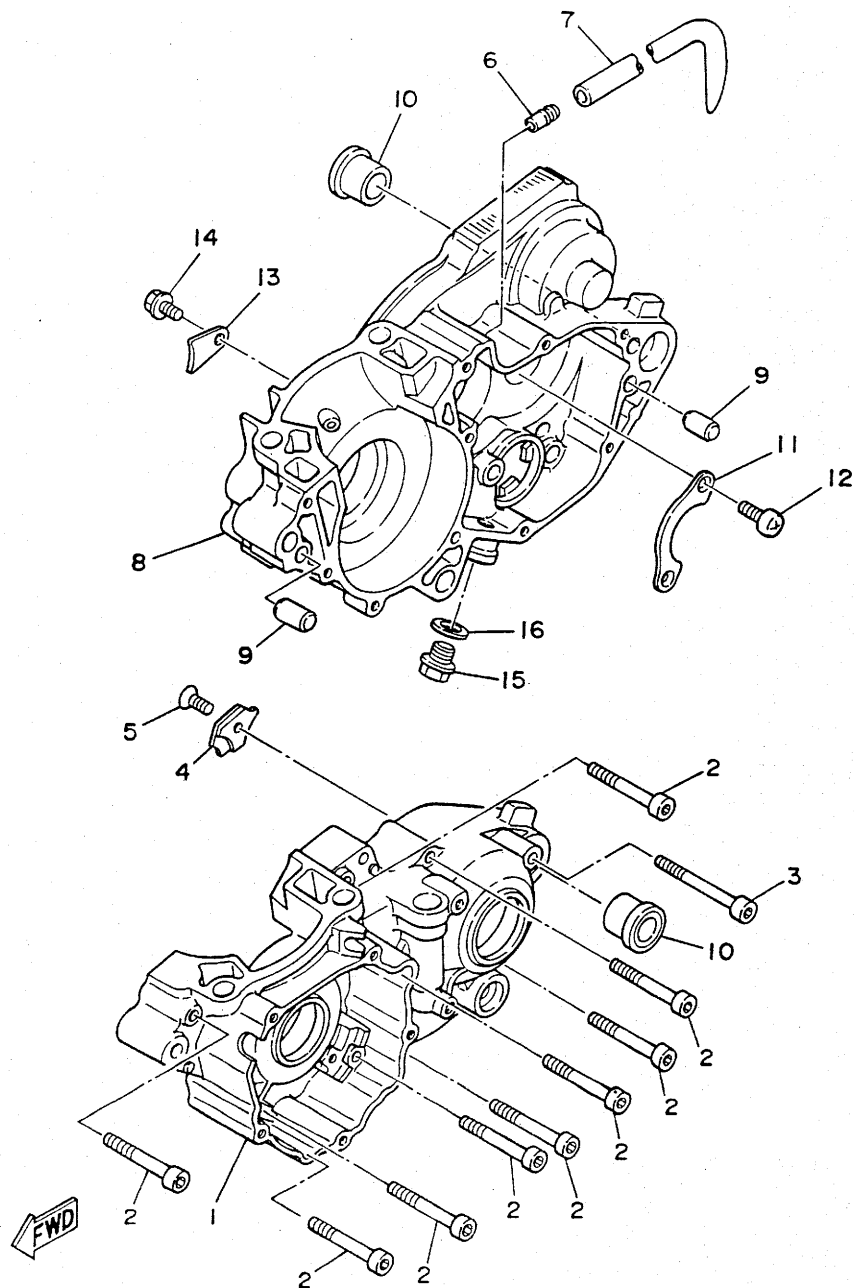


FIG. 8 EXHAUST

REF. NO.	PART NO.	DESCRIPTION	Q'TY	REMARKS
1	4DA-14610-00	EXHAUST PIPE ASSY 1	1	
2	3R4-14613-00	GASKET, exhaust pipe	1	
3	93210-56743	O-RING	1	
4	90507-20030	SPRING, tension	3	
5	565-14771-00	STAY, muffler 1	1	
6	483-14781-01	STAY, muffler 2	1	
7	95023-06012	BOLT	2	
8	95023-06010	BOLT	1	
9	95023-08012	BOLT	1	
10	3JE-14615-00	JOINT, exhaust 1	1	
11	3XK-14753-10	SILENCER, exhaust	1	
12	95023-06008	.BOLT	3	
13	3XK-1469A-10	.FIBER	1	
14	39X-14747-00	DAMPER, muffler	1	
15	90387-100Y1	COLLAR	1	
16	90201-08612	WASHER, plate	1	
17	95023-08030	BOLT	1	
18	90480-16233	GROMMET	1	
19	90387-060A7	COLLAR	1	
20	90201-06407	WASHER, plate	1	
21	90109-064F4	BOLT	1	

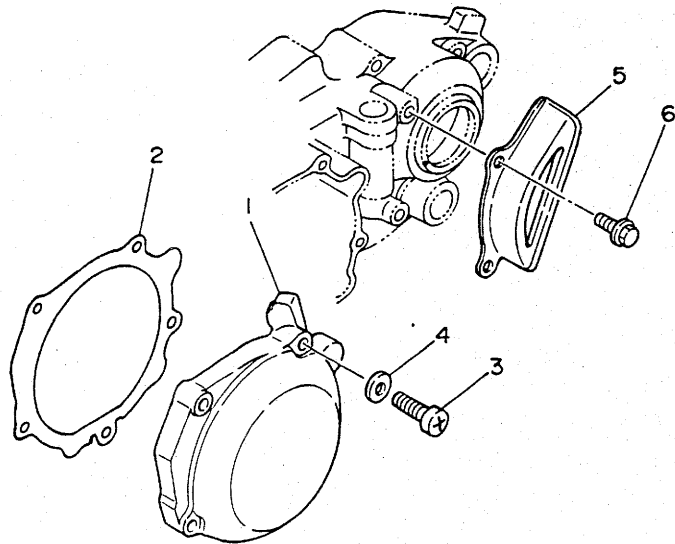
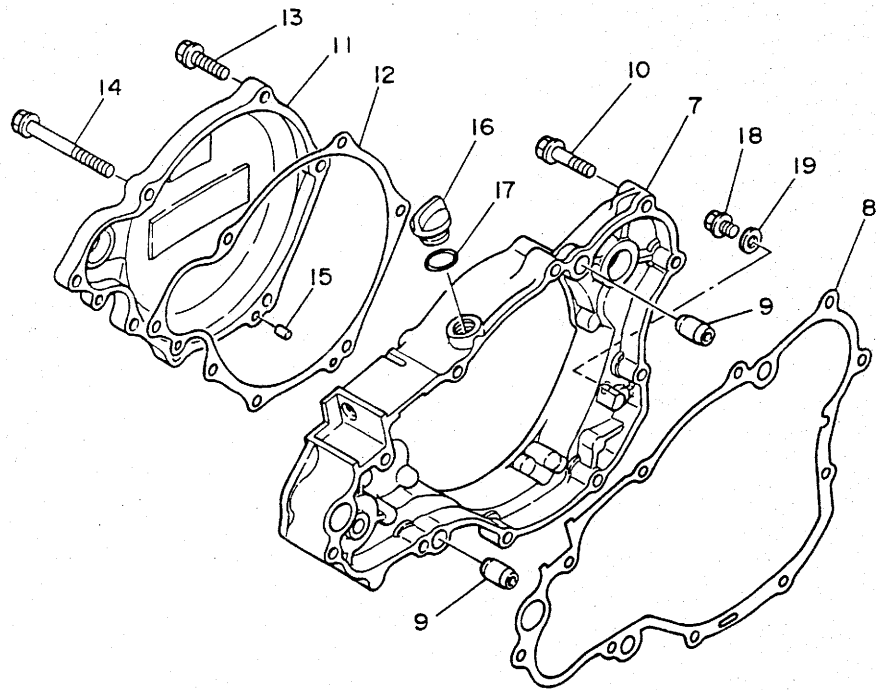
FWD

FIG. 9 CRANKCASE



REF. NO.	PART NO.	DESCRIPTION	Q'TY	REMARKS
1	2VM-15111-03	CRANKCASE 1	1	
2	91316-06050	BOLT	9	
3	91316-06070	BOLT	1	
4	3SP-15381-00	PLATE, bearing cover	1	
5	98701-06012	SCREW, flat head	1	
6	353-13115-01	CONNECTOR, suction pipe	1	
7	90445-086A8	HOSE	1	
8	2VM-15121-01	CRANKCASE 2	1	
9	99510-12016	PIN, dowel	2	
10	90387-160H4	COLLAR	2	
11	4L0-17471-00	PLATE, cover	1	
12	98501-06012	SCREW, pan head	2	
13	4V4-15118-00	HOLDER	1	
14	95811-06010	BOLT, flange	1	
15	90340-12097	PLUG, straight screw	1	
16	90430-12207	GASKET	1	

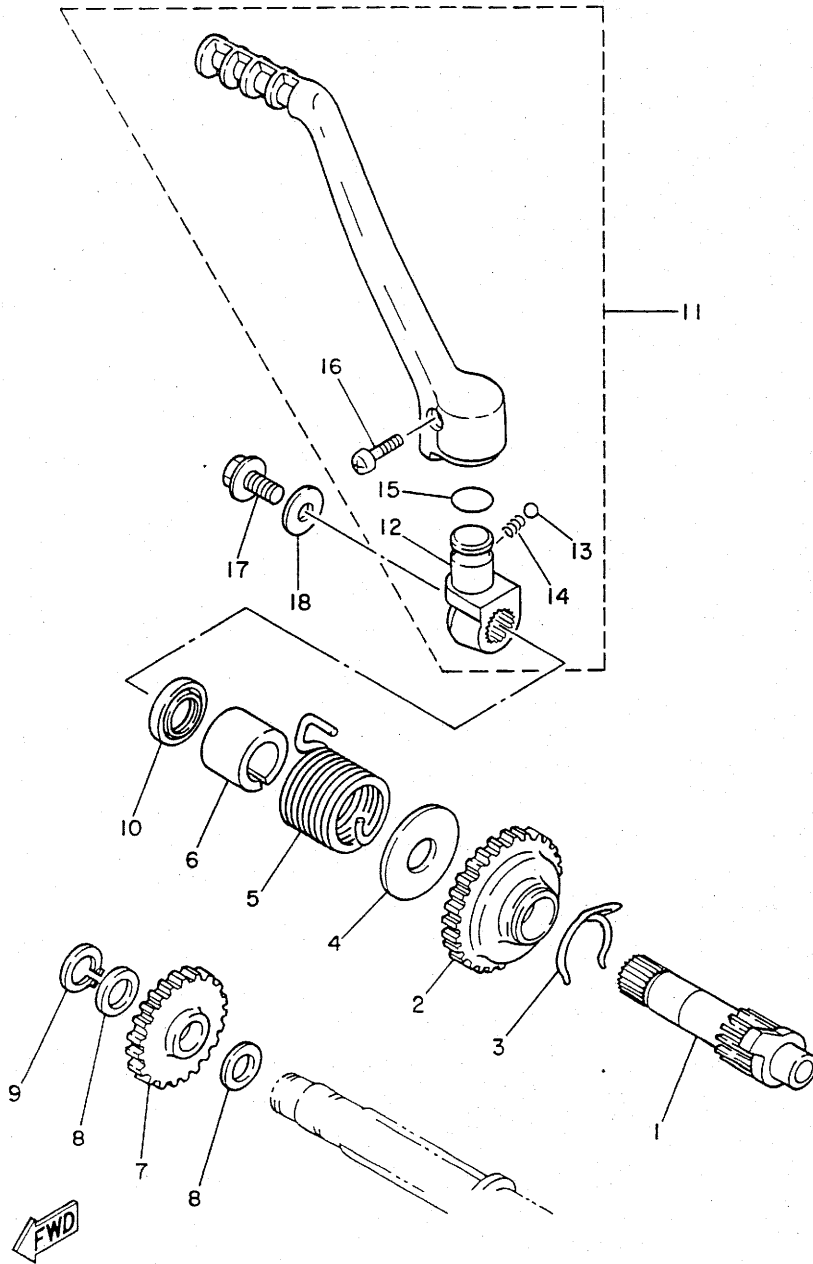
FIG. 10 CRANKCASE COVER 1



FWD

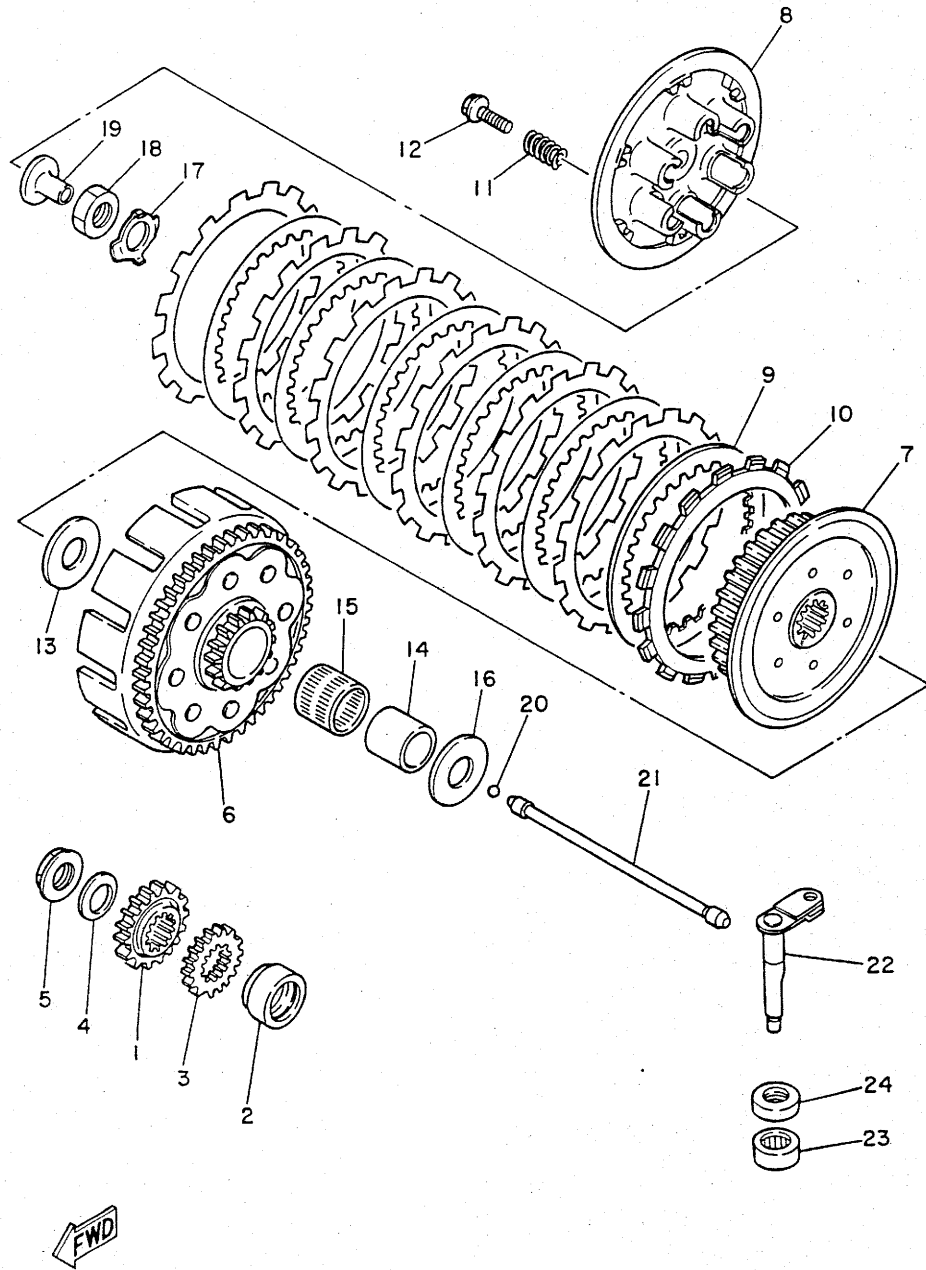
REF. NO.	PART NO.	DESCRIPTION	Q'TY	REMARKS
1	2VM-15411-00	COVER, crankcase 1	1	
2	2VM-15451-10	GASKET, crankcase cover 1	1	
3	98501-06030	SCREW, pan head	5	
4	92901-06600	WASHER, plate	5	
5	2VM-15421-00	COVER, crankcase 2	1	
6	95023-06012	BOLT	2	
7	3SP-Y1543-00	COVER, crankcase 3	1	
8	2VM-15462-10	GASKET, crankcase cover 3	1	
9	99510-12016	PIN, dowel	2	
10	95023-06030	BOLT	7	
11	4EW-15415-00	COVER, generator	1	
12	3SP-15463-10	GASKET, carburetor cover 2	1	
13	95023-06025	BOLT	5	
14	95021-06070	BOLT, flange	2	
15	93604-10011	PIN, dowel	2	
16	1G8-15362-00	PLUG, oil level	1	
17	93210-14104	O-RING	1	
18	95023-06008	BOLT	1	
19	90430-06016	GASKET	1	

FIG. 11 STARTER



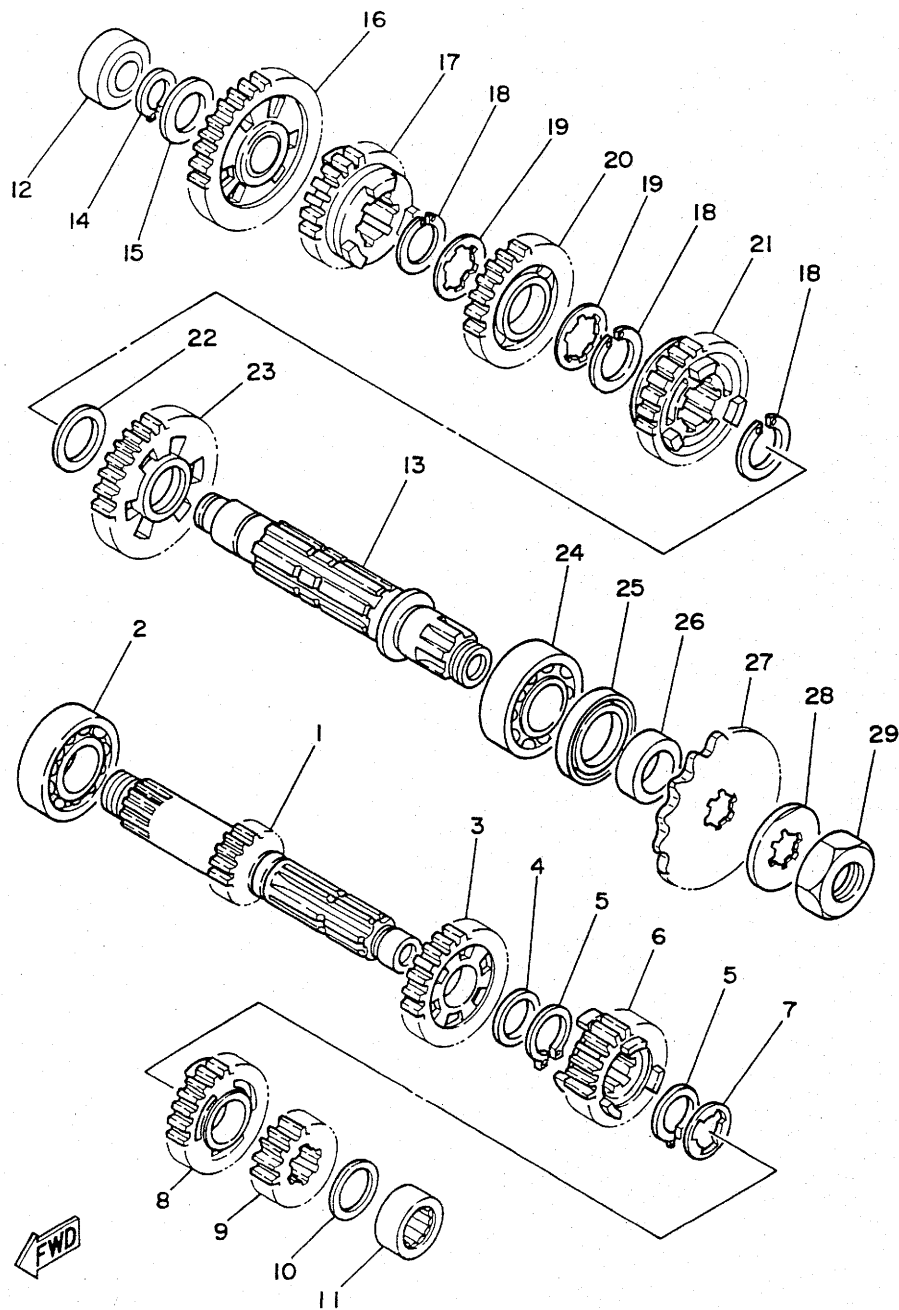
REF. NO.	PART NO.	DESCRIPTION	Q'TY	REMARKS
1	2VM-15661-00	AXLE, kick	1	
2	3R4-15641-00	GEAR, kick (26T)	1	
3	90468-26048	CLIP	1	
4	90201-20358	WASHER, plate	1	
5	90508-30743	SPRING, torsion	1	
6	2VM-15664-00	GUIDE, spring	1	
7	38V-15651-00	GEAR, kick idle (23T)	1	
8	90201-17545	WASHER, plate	2	
9	99009-17400	CIRCLIP	1	
10	93102-20309	OIL SEAL	1	
11	3SP-15620-01	KICK CRANK ASSY	1	
12	3SP-15621-01	.BOSS, kick crank	1	
13	1/4 inch	.BALL	1	
14	90501-13720	.SPRING, compression	1	
15	93210-19216	.O-RING	1	
16	90157-06048	.SCREW, pan head	1	
17	95023-08020	BOLT	1	
18	90201-087A9	WASHER, plate	1	

FIG. 12 CLUTCH



REF. NO.	PART NO.	DESCRIPTION	Q'TY	REMARKS
1	2VM-16111-00	GEAR, primary drive	1	
2	90387-252F6	COLLAR	1	
3	3XK-11956-00	GEAR, governor drive	1	
4	90208-18025	WASHER, conical spring	1	
5	90179-18172	NUT	1	
6	3SP-16150-00	PRIMARY DRIVEN GEAR COMP.	1	
7	2VM-16371-00	BOSS, clutch	1	
8	2VM-16351-01	PLATE, pressure 1	1	
9	3XK-16325-00	PLATE, clutch 2	6	
10	3XK-16321-00	PLATE, friction	7	
11	90501-23598	SPRING, compression	6	
12	90159-06016	SCREW, with washer	6	
13	2K7-16154-00	PLATE, thrust 1	1	
14	2VM-16181-00	SPACER 1	1	
15	93310-230T7	BEARING, cylindrical	1	
16	3SP-16154-00	PLATE, thrust 1	1	
17	90215-20231	WASHER, lock	1	
18	90170-20255	NUT	1	
19	2VM-16356-00	ROD, push 1	1	
20	11/32 inch	BALL	1	
21	3SP-16357-00	ROD, push 2	1	
22	4DA-16381-00	PUSH LEVER COMP.	1	
23	93315-11206	BEARING, cylindrical	1	
24	93102-12224	OIL SEAL	1	

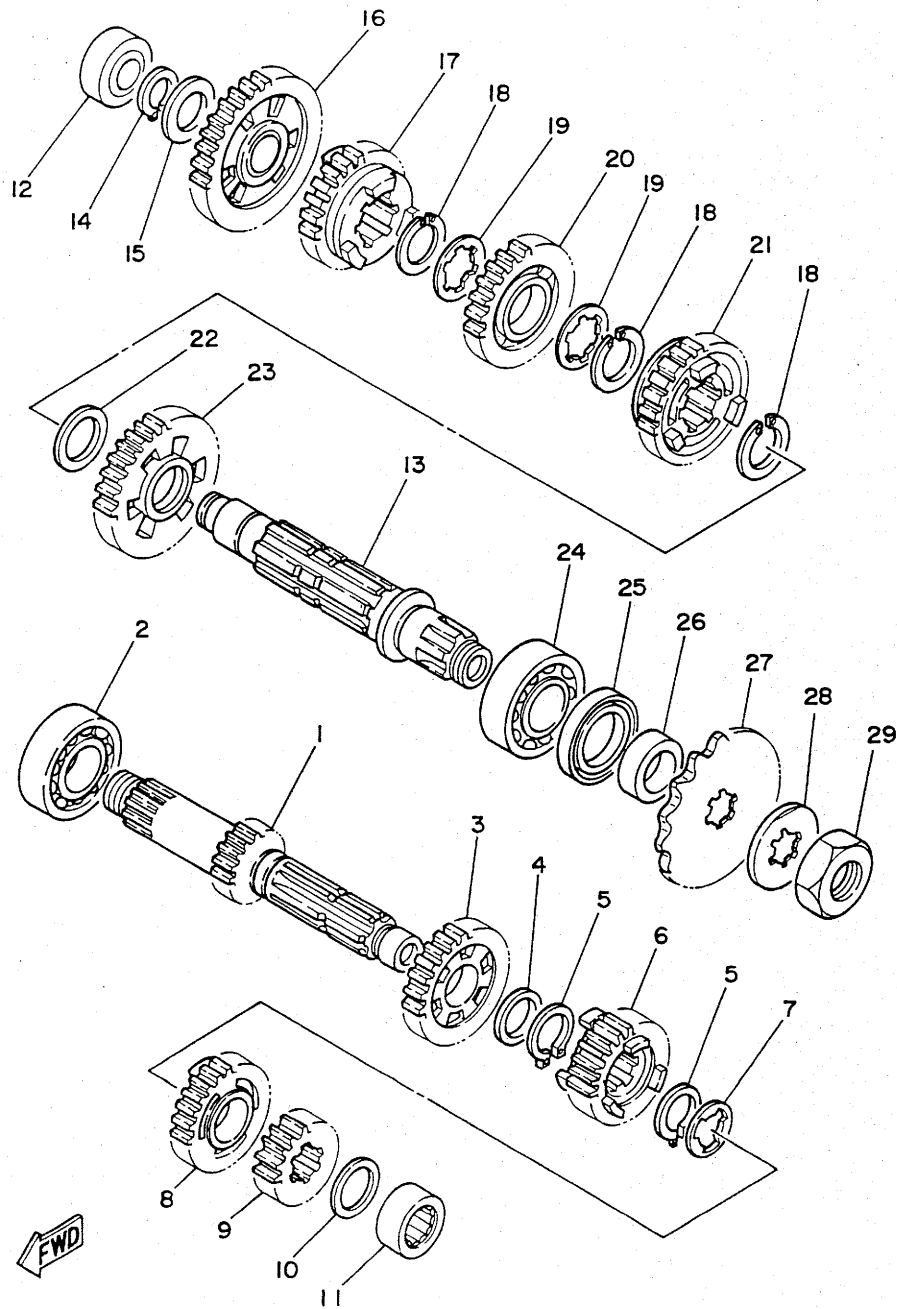
FIG. 13 TRANSMISSION



REF. NO.	PART NO.	DESCRIPTION	Q'TY	REMARKS
1	3RB-17411-00	AXLE, main (14T)	1	
2	93306-20540	BEARING	1	
3	3RB-17151-00	GEAR, 5th pinion (25T)	1	
4	90201-22555	WASHER, plate	1	
5	93410-22039	CIRCLIP	2	
6	3RB-17131-00	GEAR, 3rd pinion	1	
7	90209-18135	WASHER	1	
8	3RB-17141-10	GEAR, 4th pinion	1	
9	2VM-17121-01	GEAR, 2nd pinion (17T)	1	
10	90209-17311	WASHER	1	
11	93311-41734	BEARING, cylindrical	1	
12	93311-62035	BEARING, cylindrical	1	
13	2VM-17421-00	AXLE, drive	1	
14	93410-20038	CIRCLIP	1	
15	90201-20278	WASHER, plate	1	
16	3RB-17211-00	GEAR, 1st wheel (32T)	1	
17	3RB-17251-00	GEAR, 5th wheel (21T)	1	
18	93440-25084	CIRCLIP	3	
19	90209-22082	WASHER	2	
20	3RB-17231-00	GEAR, 3rd wheel	1	
21	3RB-17241-10	GEAR, 4th wheel	1	
22	90201-253K0	WASHER, plate (T=1.0)	1	
23	2VM-17221-00	GEAR, 2nd wheel (29T)	1	
24	93306-20574	BEARING	1	
25	93102-32M07	OIL SEAL	1	
26	90387-25663	COLLAR	1	
27	93834-14049	SPROCKET, drive 14T	1	STD
	93834-13029	SPROCKET, drive 13T	1	AP

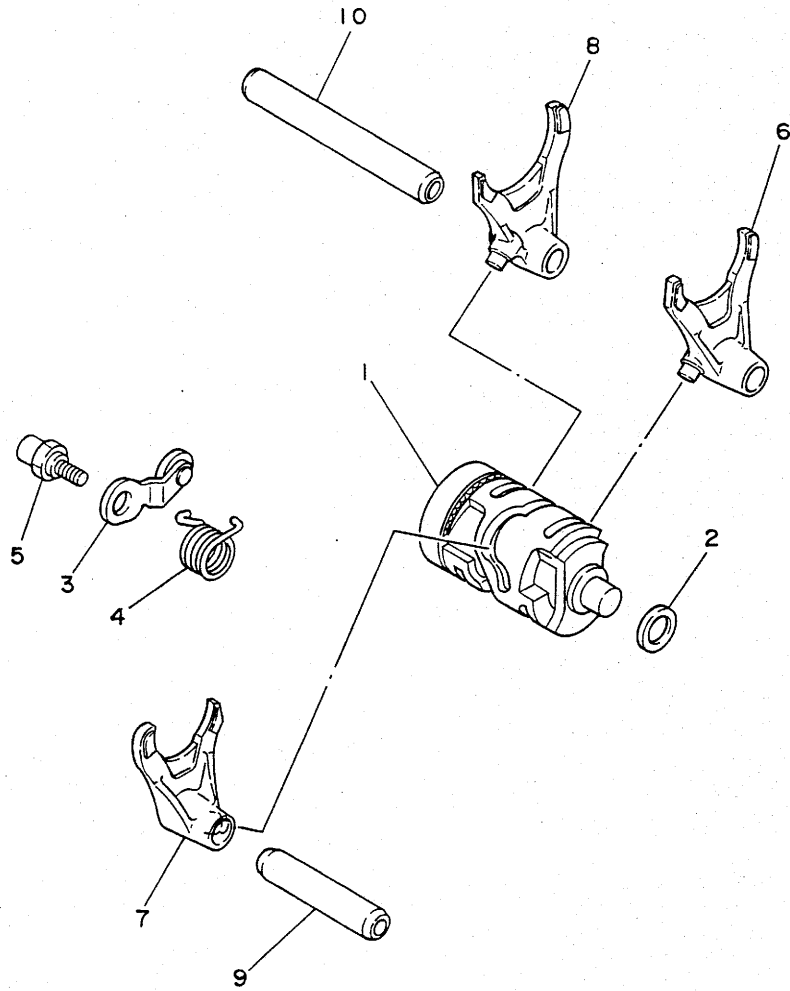


FIG. 13 TRANSMISSION



REF. NO.	PART NO.	DESCRIPTION	Q'TY	REMARKS
27	93834-15075	SPROCKET, drive 15T (1W41746150)	1	AP
28	90215-21239	WASHER, lock	1	
29	90179-20255	NUT	1	

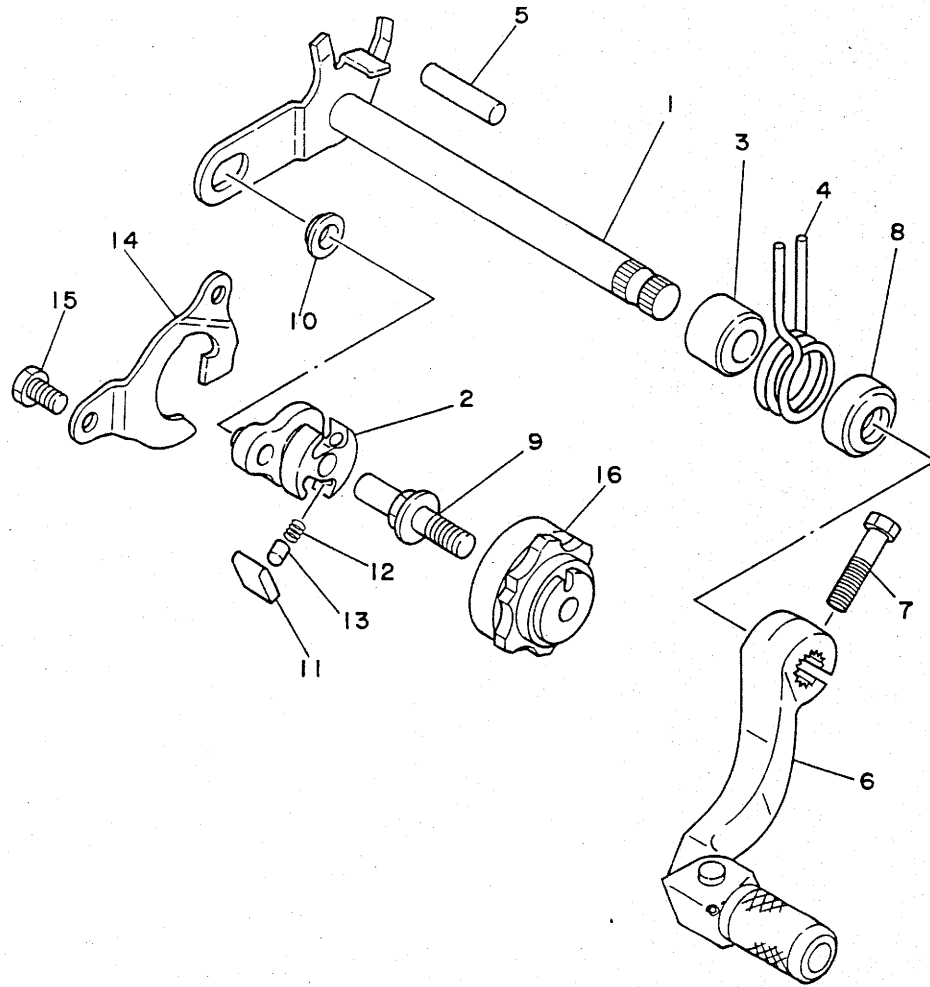
FIG. 14 SHIFT CAM. FORK



REF. NO.	PART NO.	DESCRIPTION	Q'TY	REMARKS
1	3XK-18540-01	SHIFT CAM ASSY	1	
2	90201-12166	WASHER, plate	1	
3	3XK-18140-00	STOPPER LEVER ASSY	1	
4	90508-26561	SPRING, torsion	1	
5	3XK-18177-00	BOLT, stopper	1	
6	2VM-18511-00	FORK, shift 1	1	
7	2VM-18512-00	FORK, shift 2	1	
8	2VM-18513-00	FORK, shift 3	1	
9	1LX-18531-00	BAR, shift fork guide 1	1	
10	34K-18535-00	BAR, shift fork guide 2	1	

FWD

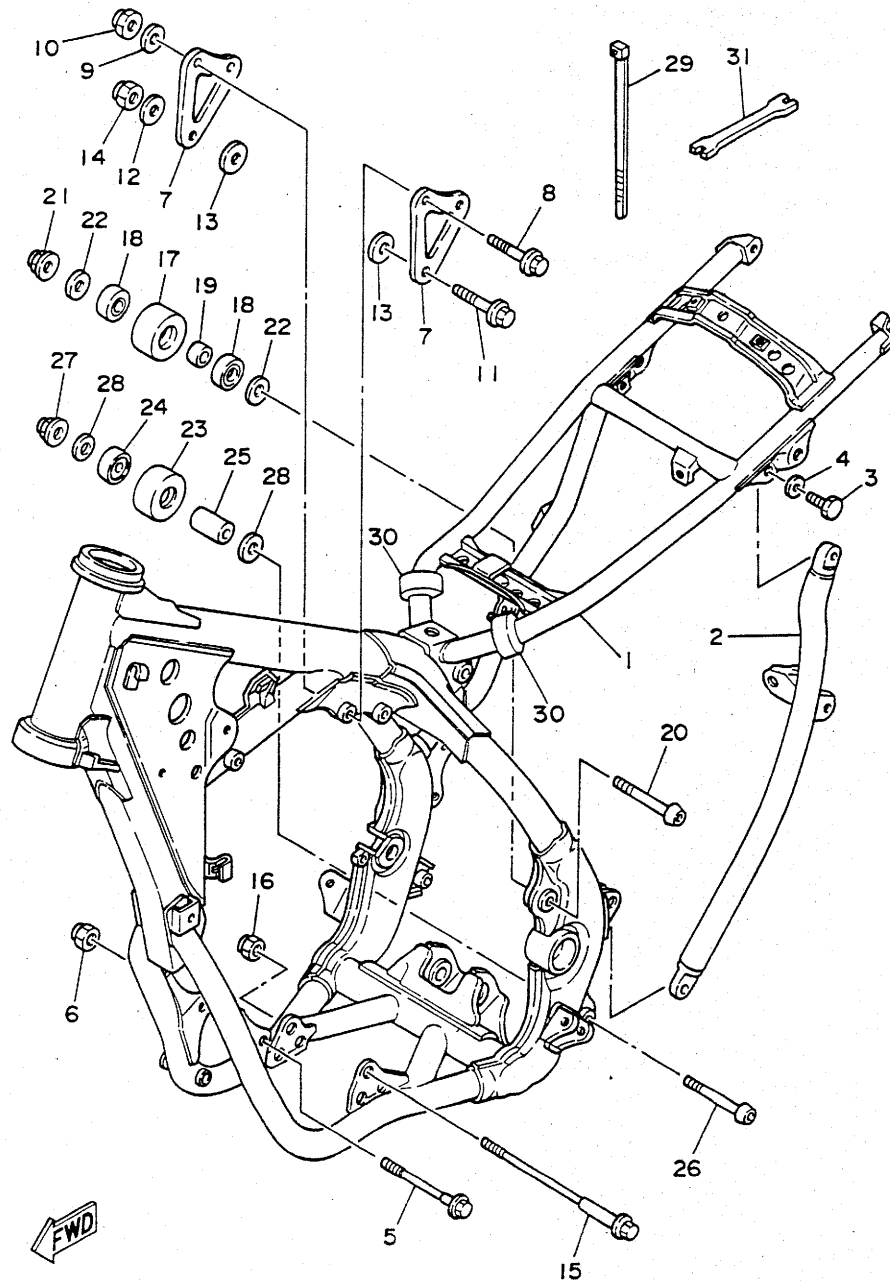
FIG. 15 SHIFTER



REF. NO.	PART NO.	DESCRIPTION	Q'TY	REMARKS
1	3XK-18101-01	SHIFT SHAFT ASSY	1	
2	3XK-18122-00	LEVER, shift 2	1	
3	90560-12280	SPACER	1	
4	90508-291A8	SPRING, torsion	1	
5	93608-33046	PIN, dowel	1	
6	2VM-18110-00	SHIFT PEDAL ASSY	1	
7	97011-06025	BOLT	1	
8	93102-12106	OIL SEAL (SD 12-22-5 HS)	1	
9	3XJ-18173-00	PIN, shift	1	
10	3XJ-18178-00	ROLLER, shift lever	1	
11	3XJ-18182-00	PAWL, shifter	2	
12	90501-05265	SPRING, compression	2	
13	3XJ-18184-00	PIN, pawl	2	
14	4DA-18172-00	GUIDE, shift	1	
15	90101-06664	BOLT	2	
16	3XJ-18185-00	SEGMENT	1	

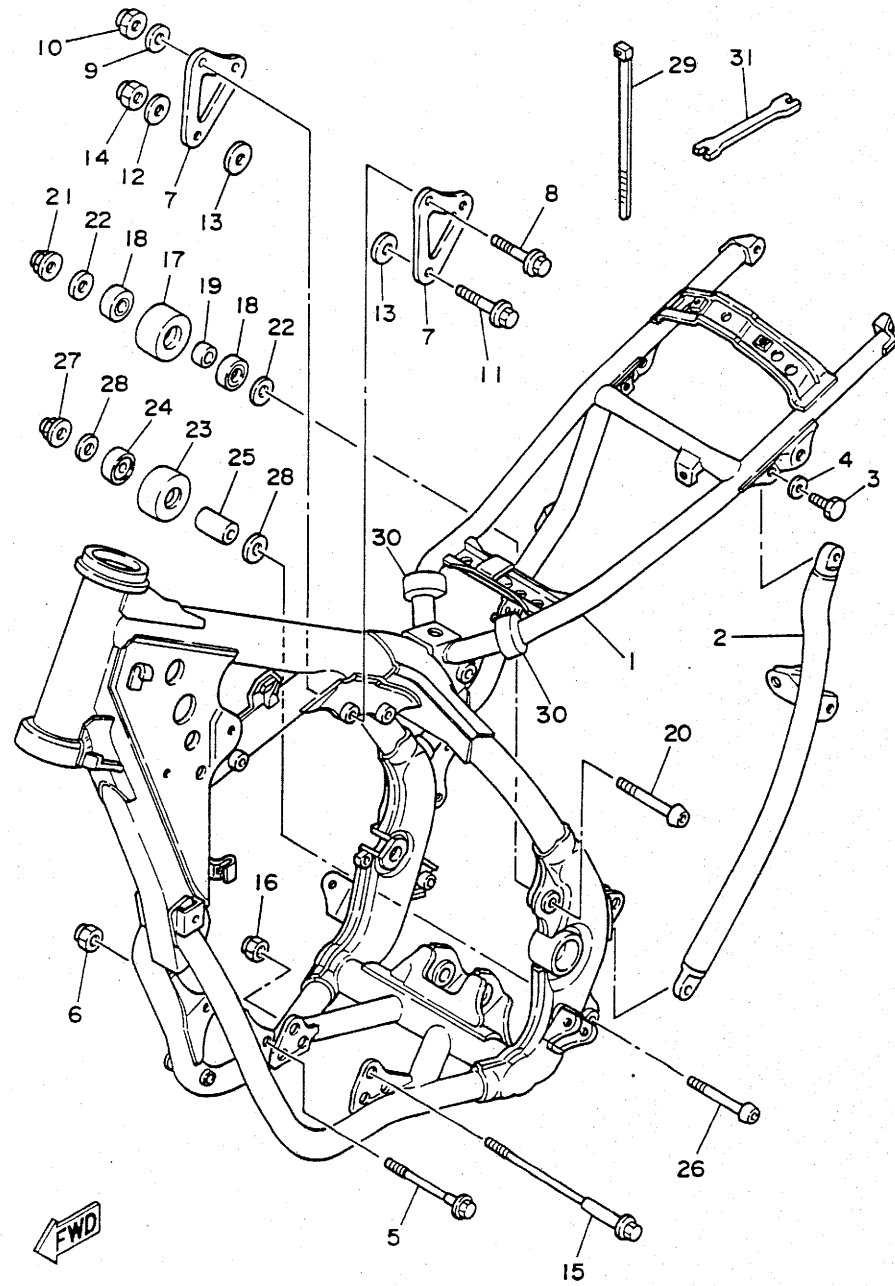
FWD

FIG. 16 FRAME



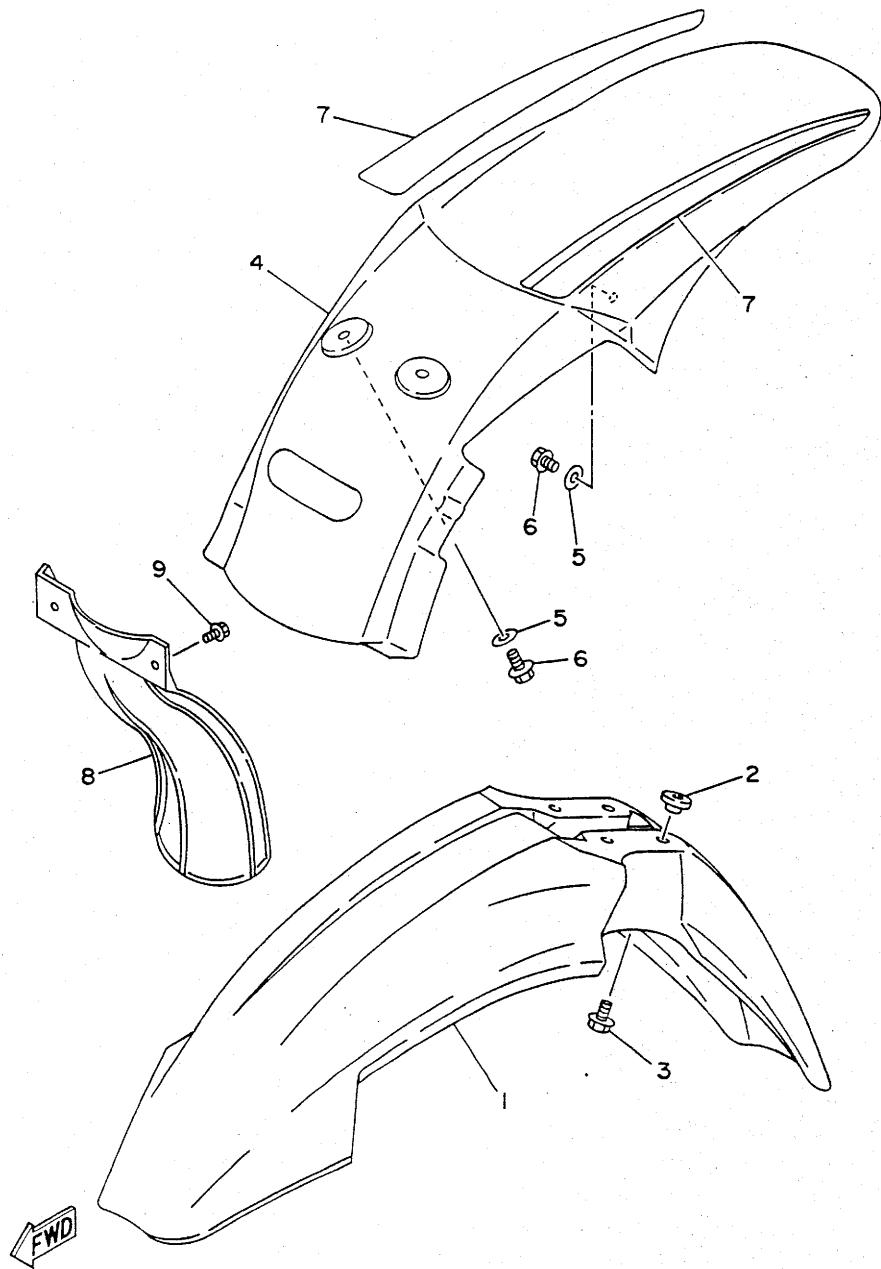
REF. NO.	PART NO.	DESCRIPTION	Q'TY	REMARKS
1	4DA-21110-01-UJ	FRAME COMP.	1	RADICAL WHITE
2	3XK-21123-00-T9	BACK, stay lh.	1	COMPETITION SILVER
3	90101-08461	BOLT	2	
4	90201-080E2	WASHER, plate	2	
5	90105-08592	BOLT, washer based	1	
6	95611-08200	NUT, self-locking	1	
7	3SP-21425-00	BRACKET, rear upper l	2	
8	95811-08055	BOLT, flange	2	
9	90202-08022	WASHER, plate	2	
10	95601-08200	NUT, self-locking	2	
11	91011-10055	BOLT, flange	1	
12	92990-10200	WASHER, plain	1	
13	90201-101J1	WASHER, plate	2	
14	95601-10200	NUT, self-locking	1	
15	91011-10120	BOLT, flange	1	
16	95611-10200	NUT, self-locking	1	
17	3JD-22178-00	TENSIONER	1	
18	93300-60804	BEARING	2	
19	90387-087K5	COLLAR	1	
20	92011-08070	BOLT, button head	1	
21	95601-08200	NUT, self-locking	1	
22	90201-081A6	WASHER, plate	2	
23	3JD-22178-10	TENSIONER	1	
24	93300-60804	BEARING	1	
25	90387-086N4	COLLAR	1	
26	92011-08070	BOLT, button head	1	
27	95601-08200	NUT, self-locking	1	
28	90201-081A6	WASHER, plate	2	

FIG. 16 FRAME



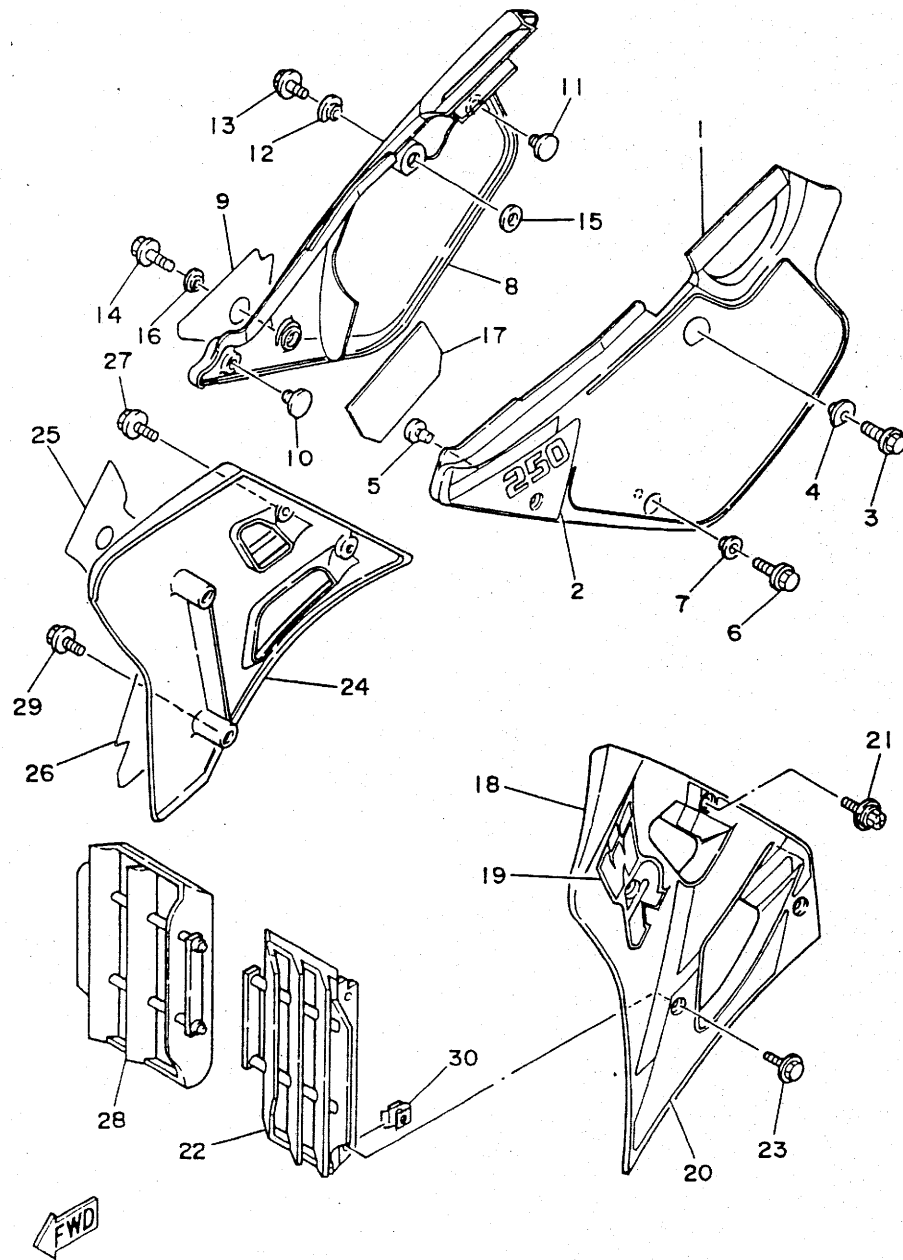
REF. NO.	PART NO.	DESCRIPTION	Q'TY	REMARKS
29	12R-82591-00	BAND	1	
30	3XJ-21717-00	DAMPER, side cover	2	
31	56A-28166-00	WRENCH, hexagon	1	

FIG. 17 FENDER



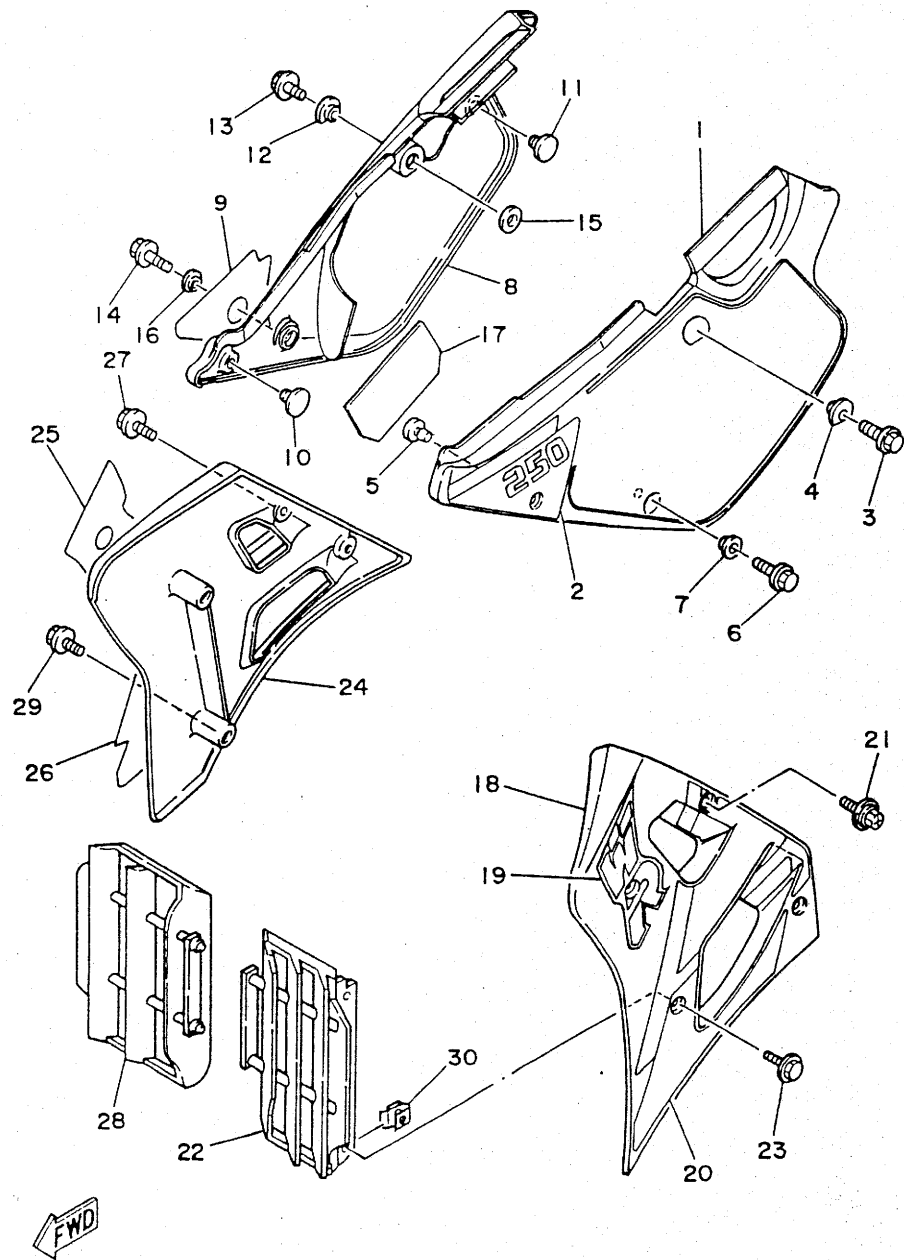
REF. NO.	PART NO.	DESCRIPTION	Q'TY	REMARKS
1	4DA-21511-00	FENDER, front	1	
2	3JD-21748-00	COLLAR	4	
3	90119-06063	BOLT, with washer	4	
4	3XJ-21611-02	FENDER, rear	1	
5	90201-06571	WASHER, plate	4	
6	90105-06553	BOLT, washer based	4	
7	4DC-2165A-00	GRAPHIC SET, rear fender	1	
8	39X-21642-00	GUARD, flap	1	
9	90119-06185	BOLT, with washer	2	

FIG. 18 SIDE COVER



REF. NO.	PART NO.	DESCRIPTION	Q'TY	REMARKS
1	3XJ-21711-01	COVER, side 1	1	
2	4DC-2173E-00	GRAPHIC 1	1	
3	95023-08020	BOLT	1	
4	90387-084X5	COLLAR	1	
5	22W-24181-00	DAMPER, locating 1	1	
6	91021-06016	BOLT, flange	1	
7	90387-064X4	COLLAR	1	
8	3XJ-21721-01	COVER, side 2	1	
9	4DC-2173F-00	GRAPHIC 2	1	
10	22W-24181-00	DAMPER, locating 1	1	
11	3JD-24181-00	DAMPER, locating 1	1	
12	90387-084X5	COLLAR	1	
13	95023-08020	BOLT	1	
14	95811-06012	BOLT, flange	1	
15	92901-08200	WASHER, plain	1	
16	90387-064X4	COLLAR	1	
17	3XJ-2174A-00	INSULATOR, side cover	1	
18	3XK-21731-01	COVER, side 3	1	
19	4DC-24244-10	GRAPHIC, fuel tank 1	1	
20	4DC-24230-00	GRAPHIC SET	1	
21	90119-06192	BOLT, with washer	2	
22	3XJ-2172A-00	PANEL 1	1	
23	90119-05193	BOLT, with washer	2	
24	3XK-21741-01	COVER, side 4	1	
25	4DC-24245-10	GRAPHIC, fuel tank 2	1	
26	4DC-24250-02	GRAPHIC SET	1	
27	90119-06192	BOLT, with washer	2	
28	3XJ-2172A-00	PANEL 1	1	

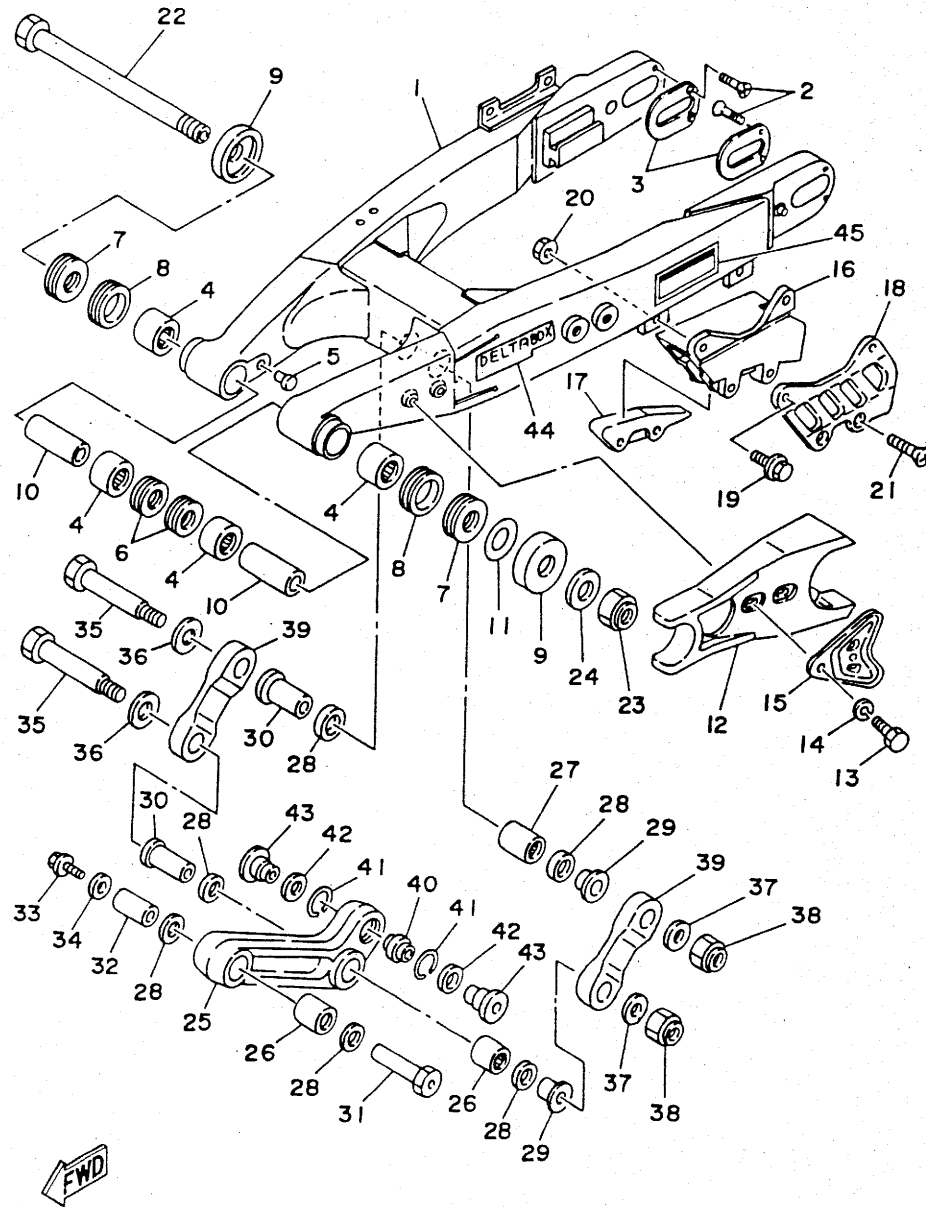
FIG. 18 SIDE COVER



REF. NO.	PART NO.	DESCRIPTION	Q'TY	REMARKS
29	90119-05193	BOLT, with washer	2	
30	22W-21791-00	NUT	4	



FIG. 19 REAR ARM



REF. NO.	PART NO.	DESCRIPTION	Q'TY	REMARKS
1	4DC-22110-00	REAR ARM COMP.	1	
2	90151-04048	SCREW, countersunk	4	
3	3XJ-22355-00	PATCH A	2	
4	93317-22262	BEARING, cylindrical	4	
5	90338-10150	PLUG	2	
6	93106-22019	OIL SEAL (DC 22-28-8)	2	
7	93342-22208	BEARING, thrust	2	
8	93108-35004	OIL SEAL (35-41-8)	2	
9	3R4-22129-00	COVER, thrust 2	2	
10	90380-16158	BUSH, solid	2	
11	156-22127-00	SHIM (0.3T)	1	UN
12	3JD-22151-00	SEAL, guard	1	
13	95023-06020	BOLT	2	
14	92990-06100	WASHER, spring	2	
15	3JD-22156-00	WASHER, plate	1	
16	3XP-22199-00	SUPPORT, chain	1	
17	3JD-22147-00	PROTECTOR, chain	1	
18	3JD-22128-00	COVER, thrust 1	1	
19	90105-06601	BOLT, washer based	2	
20	95701-06500	NUT, flange	2	
21	98701-06050	SCREW, flat head	2	
22	1LX-22141-00	SHAFT, pivot	1	
23	90185-16127	NUT, self-locking	1	
24	90201-164H4	WASHER, plate	1	
25	3XJ-2217A-00	ARM, relay	1	
26	93315-22046	BEARING, cylindrical	2	
27	93315-22046	BEARING, cylindrical	1	
28	93109-20029	OIL SEAL	6	

FIG. 19 REAR ARM

REF. NO.	PART NO.	DESCRIPTION	Q'TY	REMARKS
29	90387-164N2	COLLAR	2	
30	90387-164N3	COLLAR	2	
31	90179-10544	NUT	1	
32	90387-167R5	COLLAR	1	
33	95811-10016	BOLT, flange	1	
34	90201-106F2	WASHER, plate	1	
35	90109-142F4	BOLT	2	
36	90201-164H4	WASHER, plate	2	
37	90201-14740	WASHER, plate	2	
38	90185-14070	NUT, self-locking	2	
39	3XJ-2217F-00	ROD, connecting 1	2	
40	93399-99921	BEARING	1	
41	93440-30113	CIRCLIP	2	
42	3XJ-22475-00	SEAL, dust	2	
43	90387-103X9	COLLAR	2	
44	3XJ-2218A-00	EMBLEM, rear arm	2	

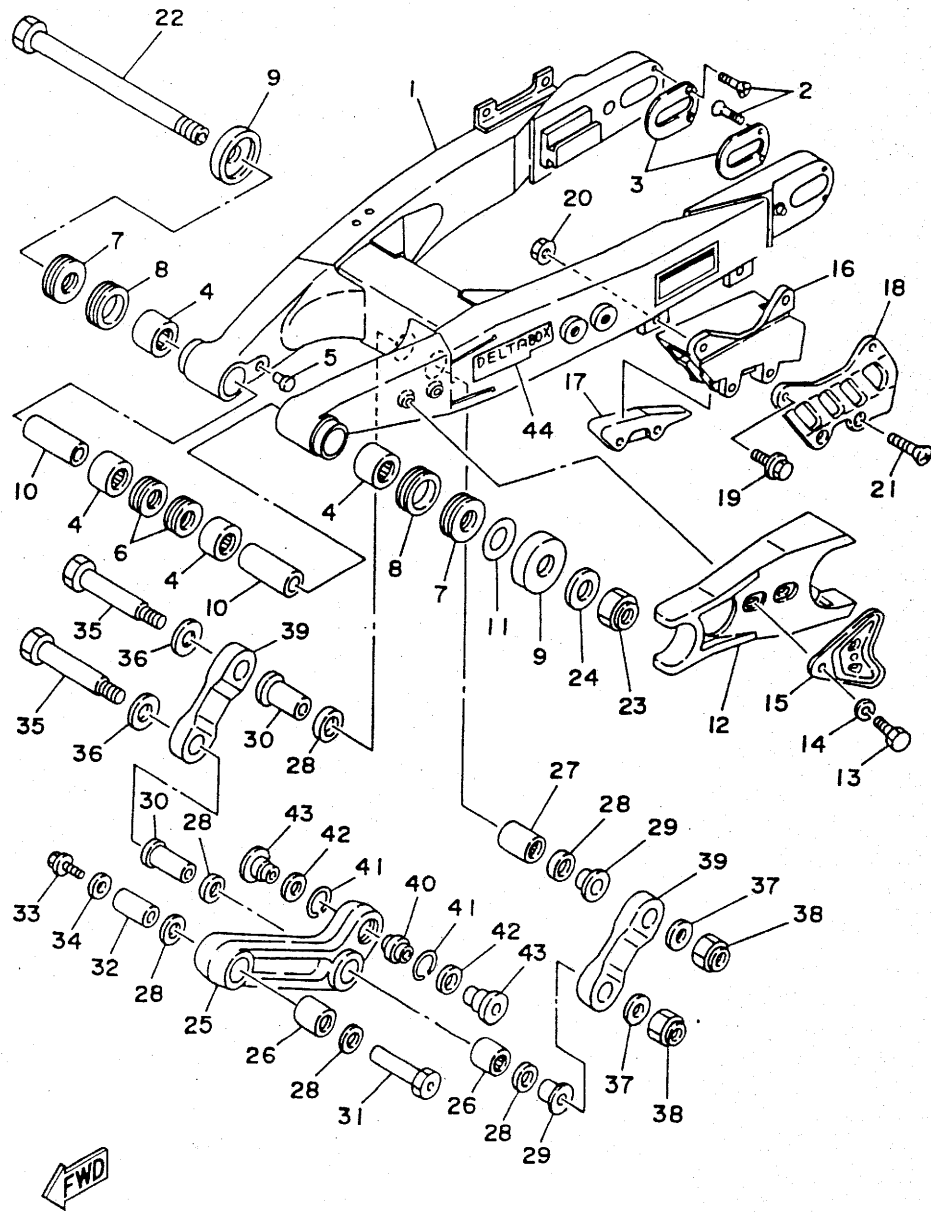
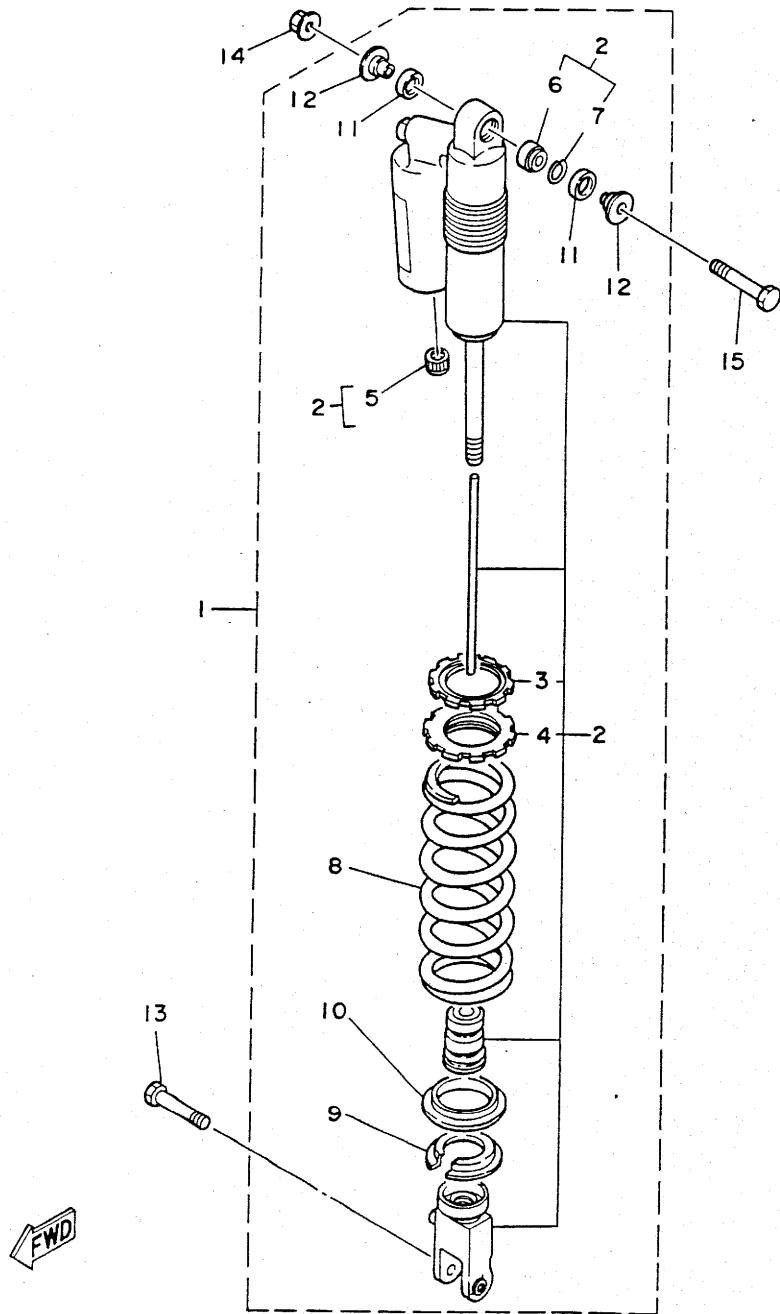
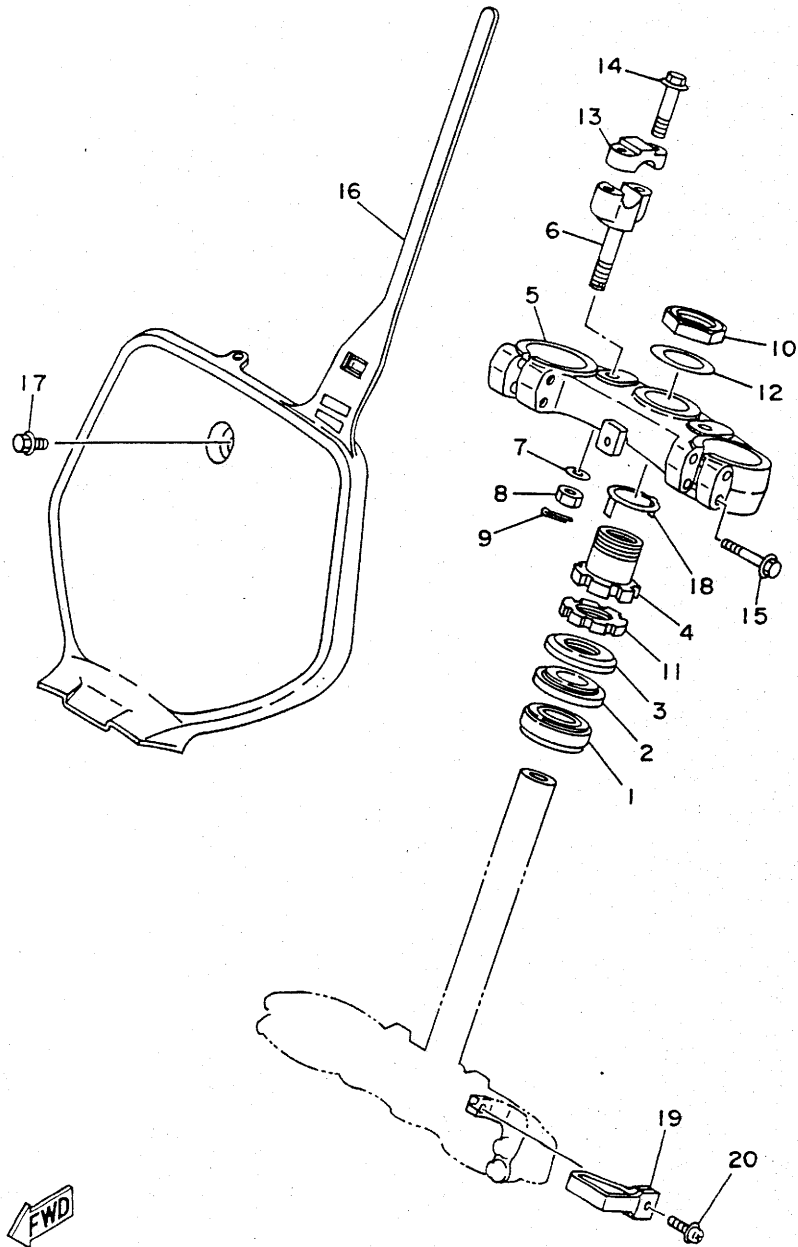


FIG. 20 REAR SUSPENSION



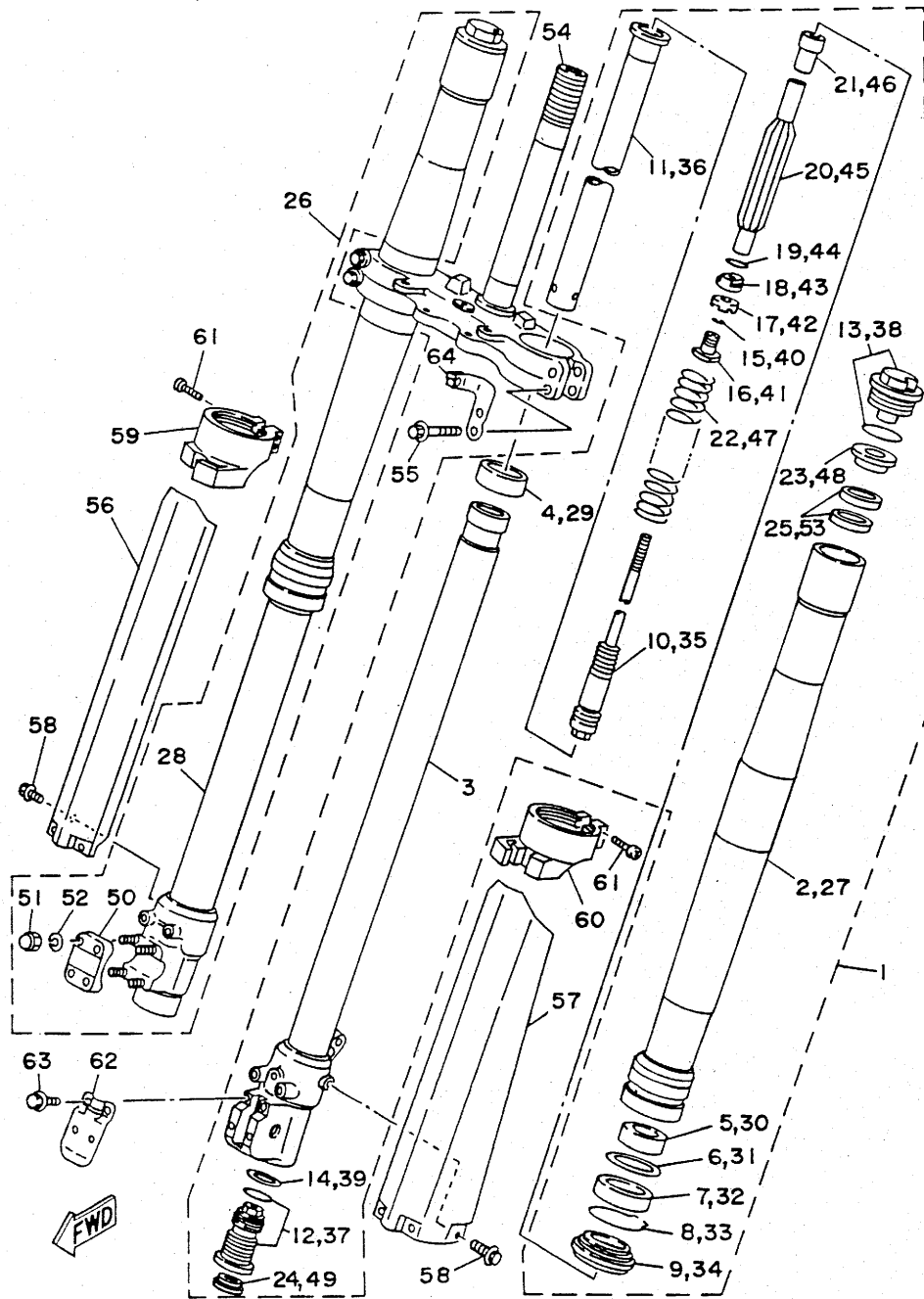
REF. NO.	PART NO.	DESCRIPTION	Q'TY	REMARKS
1	4DC-22210-00	SHOCK ABSORBER ASSY, rear	1	
2	4DC-22201-00	.DAMPER SUB ASSY	1	
3	3SP-22234-00	..GUIDE, spring 3	1	
4	3SP-22213-00	..SEAT, spring upper	1	
5	24M-23184-00	..CAP, air valve	1	
6	3JD-22216-00	..BUSH, rear shock absorber	1	
7	43M-22274-00	..RING, stop	1	
8	3XJ-22212-11	.SPRING (K=4.8)	1	
9	3JD-22214-00	.GUIDE, spring 1	1	
10	3JD-22224-00	.GUIDE, spring 2	1	
11	3JD-22475-00	.SEAL, dust	2	
12	3XJ-22253-00	.COLLAR, distance	2	
13	90105-10614	BOLT, washer based	1	
14	95611-10200	NUT, self-locking	1	
15	3SP-22241-00	BOLT 1	1	

FIG. 21 STEERING



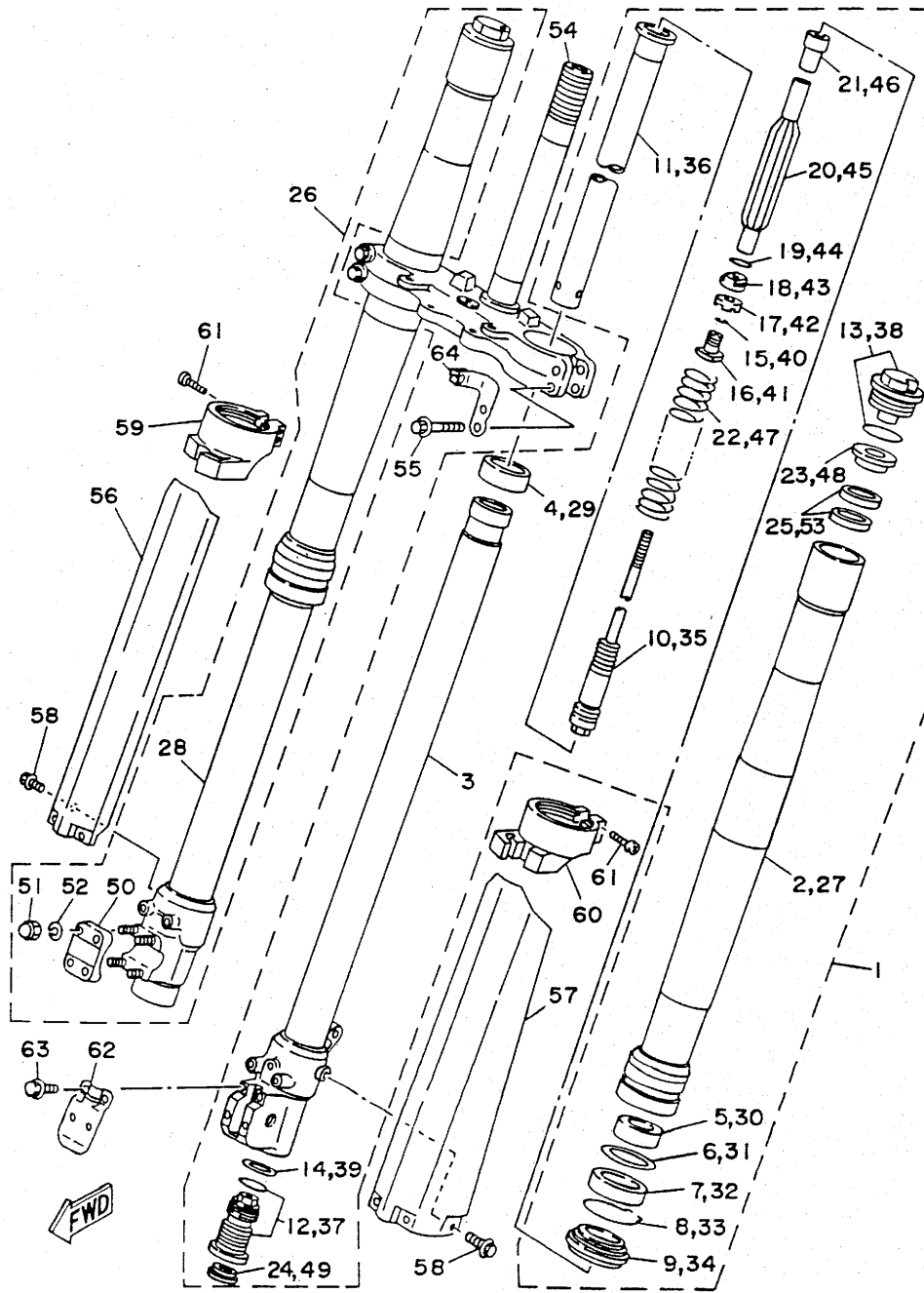
REF. NO.	PART NO.	DESCRIPTION	Q'TY	REMARKS
1	93332-00067	BEARING	1	
2	93332-00068	BEARING	1	
3	2HG-23416-00	COVER, ball race 2	1	
4	90179-28603	NUT	1	
5	4DA-23435-01	CROWN, handle	1	
6	3SP-23442-00	HOLDER, handle lower	2	
7	92990-12200	WASHER, plain	2	
8	95611-12100	NUT, u	2	
9	91401-25020	PIN, cotter	2	
10	90170-36394	NUT	1	
11	90179-28602	NUT	1	
12	90201-365M5	WASHER, plate	1	
13	3SP-23441-00	HOLDER, handle upper	2	
14	95023-08035	BOLT	4	
15	95021-08040	BOLT, flange	4	
16	4DA-23485-01	PLATE, number	1	
17	90119-06185	BOLT, with washer	1	
18	3SP-23418-00	WASHER, special	1	
19	4DA-23389-00	GUIDE, cable	1	
20	90159-05122	SCREW, with washer	1	

FIG. 22 FRONT FORK



REF. NO.	PART NO.	DESCRIPTION	Q'TY	REMARKS
1	4DC-23102-M0	FRONT FORK ASSY (L.H)	1	
2	4DA-23136-L0	.TUBE, outer 2	1	
3	4DA-23120-L0	.INNER TUBE COMP. 2	1	
4	3XJ-23171-L0	.PISTON, front fork	1	
5	3XJ-23125-L0	.METAL, slide 1	1	
6	4V4-23146-L0	.WASHER, oil seal	1	
7	4DA-23145-L0	.OIL SEAL	1	
8	4V4-23153-L0	.RING, snap	1	
9	4DA-23144-L0	.SEAL, dust	1	
10	4DA-2314A-L0	.PISTON ROD ASSY	1	
11	4DA-23170-L0	.CYLINDER COMP., front fork	1	
12	4DC-2316A-M0	.VALVE COMP.	1	
13	4DA-23111-L0	.BOLT, cap	1	
14	2HH-23158-L0	.GASKET	1	
15	3XJ-23153-L0	.RING, snap	2	
16	3XJ-23113-L0	.COLLAR	1	
17	3XJ-23166-L0	.SPACER, oil lock	1	
18	3XJ-23778-L0	.NUT	1	
19	36Y-23147-10	.O-RING	1	
20	3XJ-23142-L0	.SEAT, spring upper	1	
21	4DA-23778-L0	.NUT	1	
22	4DA-23141-L0	.SPRING, front fork (k=0.390)	1	
23	3XJ-23143-L0	.SEAT, spring lower	1	
24	3JD-2312G-L0	.PLUG	1	
25	3XJ-23364-L0	.COLLAR 2	2	
26	4DC-23103-M0	FRONT FORK ASSY (R.H)	1	

FIG. 22 FRONT FORK



REF. NO.	PART NO.	DESCRIPTION	Q'TY	REMARKS
27	4DA-23136-L0	.TUBE, outer 2	1	
28	4DA-23110-L0	.INNER TUBE COMP. 1	1	
29	3XJ-23171-L0	.PISTON, front fork	1	
30	3XJ-23125-L0	.METAL, slide 1	1	
31	4V4-23146-L0	.WASHER, oil seal	1	
32	4DA-23145-L0	.OIL SEAL	1	
33	4V4-23153-L0	.RING, snap	1	
34	4DA-23144-L0	.SEAL, dust	1	
35	4DA-2314A-L0	.PISTON ROD ASSY	1	
36	4DA-23170-L0	.CYLINDER COMP., front fork	1	
37	4DC-2316A-M0	.VALVE COMP.	1	
38	4DA-23111-L0	.BOLT, cap	1	
39	2HH-23158-L0	.GASKET	1	
40	3XJ-23153-L0	.RING, snap	2	
41	3XJ-23113-L0	.COLLAR	1	
42	3XJ-23166-L0	.SPACER, oil lock	1	
43	3XJ-23778-L0	.NUT	1	
44	36Y-23147-10	.O-RING	1	
45	3XJ-23142-L0	.SEAT, spring upper	1	
46	4DA-23778-L0	.NUT	1	
47	4DA-23141-L0	.SPRING, front fork (K=0.390)	1	
48	3XJ-23143-L0	.SEAT, spring lower	1	
49	3JD-2312G-L0	.PLUG	1	
50	4DA-23167-L0	.HOLDER, axle	1	
51	5Y3-23393-00	.NUT, special	4	
52	92990-06100	.WASHER, spring	4	

FIG. 22 FRONT FORK

REF. NO.	PART NO.	DESCRIPTION	Q'TY	REMARKS
53	3XJ-23364-LO	.COLLAR 2	2	
54	4DA-23340-LO	UNDER BRACKET COMP.	1	
55	95021-08040	BOLT, flange	4	
56	4DA-2314J-LO	PROTECTOR COMP. 2	1	
57	4DA-2314H-L1	PROTECTOR COMP. 1	1	
58	3SP-23356-LO	BOLT 2	6	
59	4DA-2314G-LO	PROTECTOR GUIDE COMP. 2	1	
60	4DA-2314F-LO	PROTECTOR GUIDE COMP. 1	1	
61	4V4-23194-LO	SCREW, boot band	4	
62	3SP-2314E-LO	COVER, hose	1	
63	4DA-23346-LO	BOLT 1	1	
64	4EW-2331E-LO	GUIDE, cable	1	

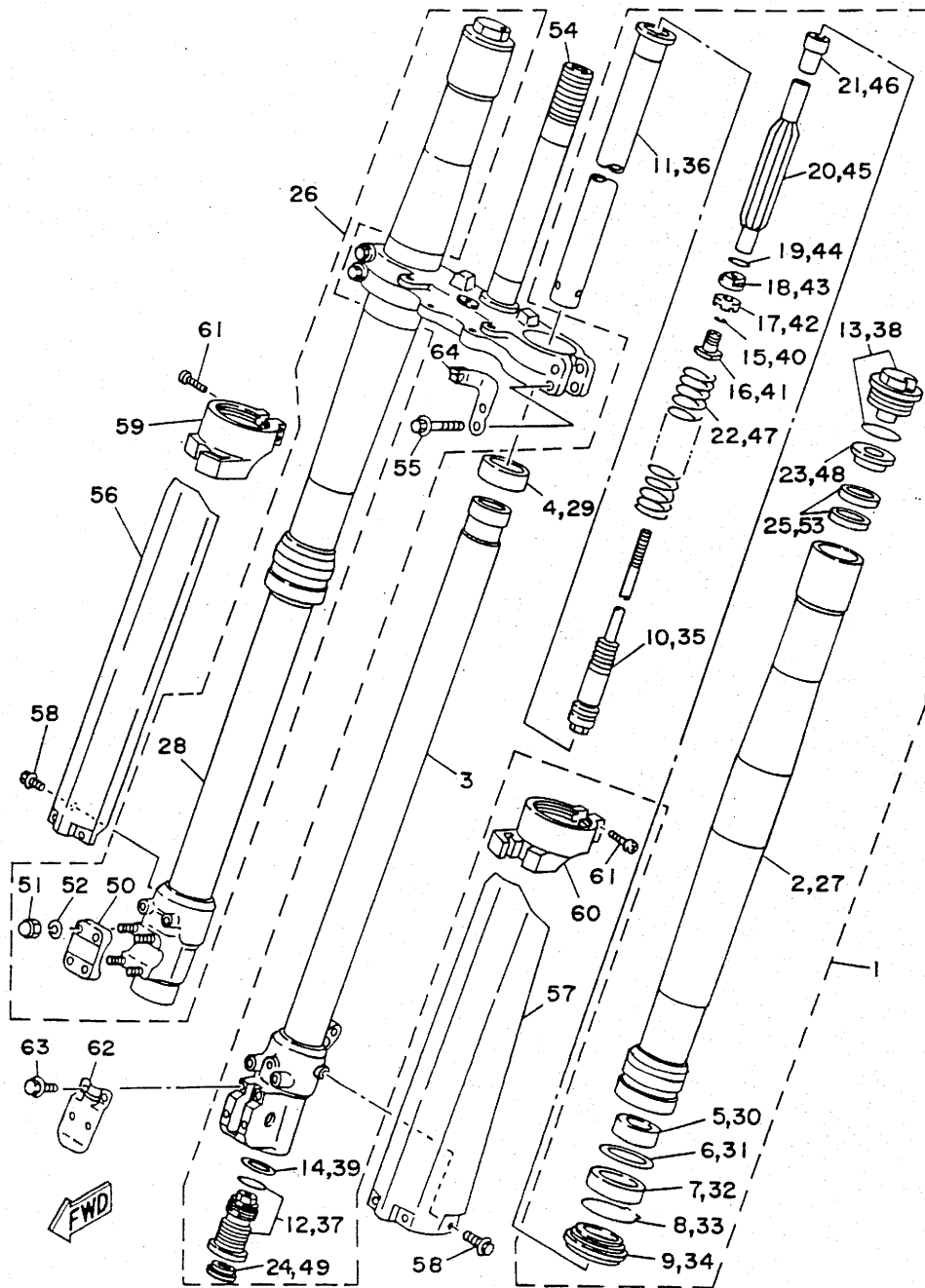
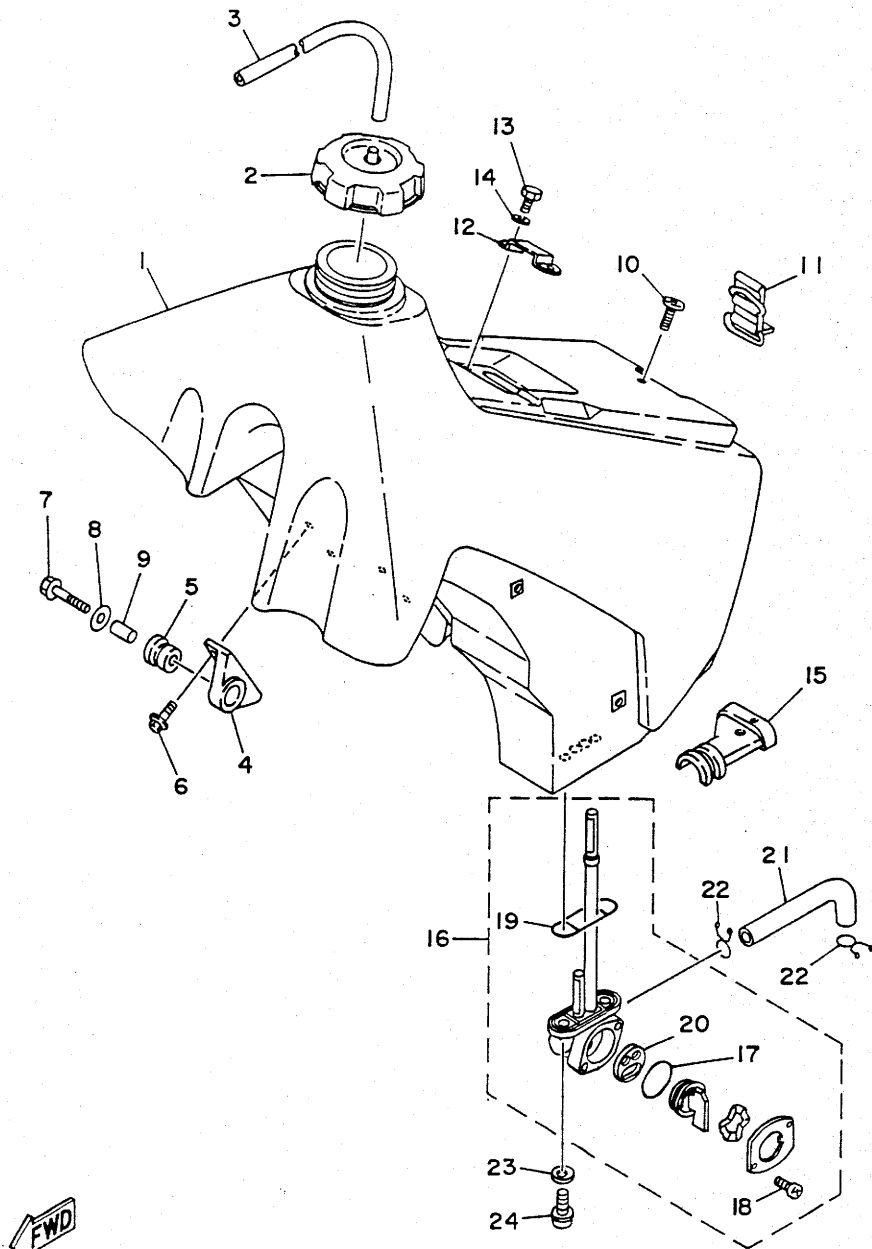


FIG. 23 FUEL TANK

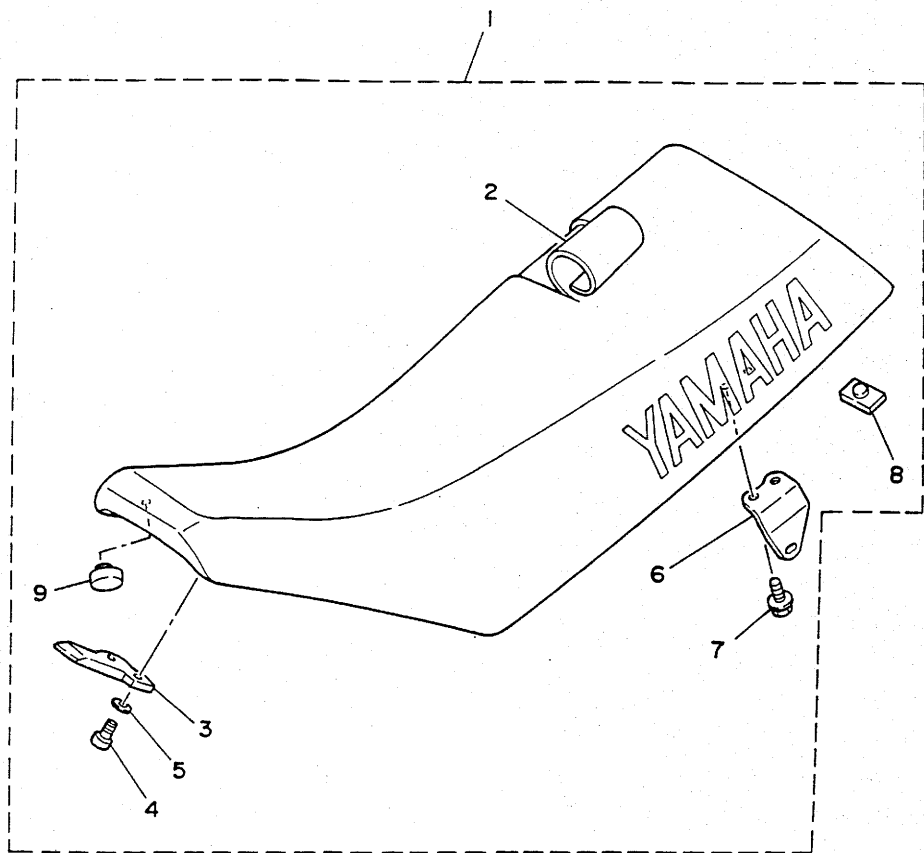


FWD

REF. NO.	PART NO.	DESCRIPTION	Q'TY	REMARKS
1	4DC-24110-01	FUEL TANK COMP.	1	
2	1UY-24610-00	CAP ASSY	1	
3	90445-09252	HOSE	1	
4	24X-24144-00	HOLDER, damper	2	
5	90480-18549	GROMMET	2	
6	95023-06016	BOLT	4	
7	95023-06035	BOLT	2	
8	90201-06697	WASHER, plate	2	
9	90387-06027	COLLAR	2	
10	98980-06020	SCREW, bind	1	
11	3SP-24173-00	BAND, tank fitting 1	1	
12	5X6-2412F-00	BRACKET, seat	1	
13	97003-06012	BOLT	2	
14	92990-06100	WASHER, spring	2	
15	1LX-24181-00	DAMPER, locating 1	1	
16	4AA-24500-00	FUEL COCK ASSY 1	1	
17	3AJ-24534-00	.SEAL, cock	1	
18	98503-03008	.SCREW, pan head	2	
19	4X8-24512-00	.O-RING	1	
20	3AJ-24523-00	.VALVE	1	
21	4AA-24311-00	PIPE, fuel 1	1	
22	90467-10008	CLIP	2	
23	90202-05193	WASHER, plate	2	
24	90149-06011	SCREW	2	



FIG. 24 SEAT

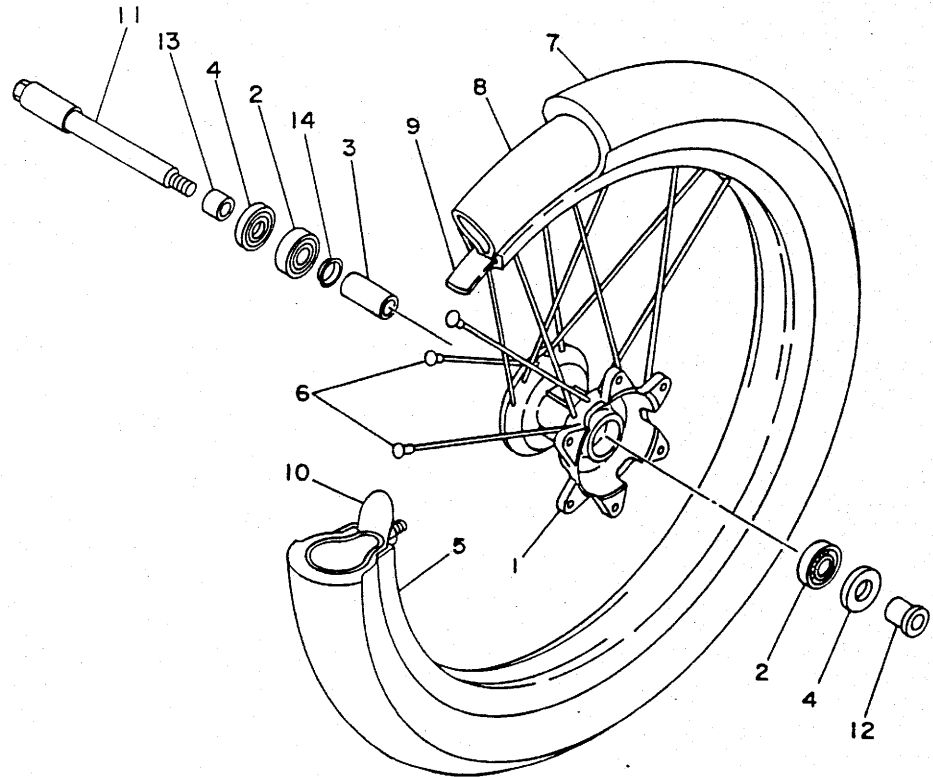


REF. NO.	PART NO.	DESCRIPTION	Q'TY	REMARKS
1	3RB-24770-20	SEMI-DOUBLE SEAT ASSY	1	
2	3RB-24731-20	.COVER, seat	1	
3	5X6-24748-10	.BRACKET, seat	1	
4	98501-06012	.SCREW, pan head	2	
5	92901-06600	.WASHER, plate	2	
6	1LX-24738-01	.BRACKET, seat	2	
7	95023-06012	.BOLT	4	
8	509-24724-00	.DAMPER, seat	1	
9	3L7-24724-00	.DAMPER, seat	2	

FWD

FIG. 25 FRONT WHEEL

REF. NO.	PART NO.	DESCRIPTION	Q'TY	REMARKS
1	4DA-25111-00	HUB, front	1	
2	93306-00316	BEARING	2	
3	90560-17379	SPACER	1	
4	93106-22032	OIL SEAL	2	
5	94416-21499	RIM (1.60-21)	1	
6	4DA-25104-00	SPOKE SET, front	1	
7	80/100 x 21	TIRE	1	
8	90/90 x 21	TUBE	1	
9	94330-21084	BAND, rim (3.00-21)	1	
10	5X2-25394-00	SPACER, bead	1	
11	4DA-25181-00	AXLE, wheel	1	
12	90387-173Y0	COLLAR	1	
13	90387-172Y9	COLLAR	1	
14	146-25116-00	FLANGE, spacer	1	



FWD

FIG. 26 FRONT BRAKE CALIPER

REF. NO.	PART NO.	DESCRIPTION	Q'TY	REMARKS
1	4EW-2582T-00	DISC, brake	1	
2	90149-06272	SCREW	6	
3	3SP-2580T-00	CALIPER ASSY (LEFT)	1	
4	3JD-W0057-00	.PISTON ASSY, caliper	1	
5	3JD-W0047-00	..CALIPER SEAL KIT	1	
6	3JD-25919-00	.SUPPORT, pad	1	
7	1UY-W0048-50	.BLEED SCREW KIT	1	
8	3SP-W0045-00	.BRAKE PAD KIT	1	
9	3GD-25933-00	.PIN, pad	2	
10	90105-08659	BOLT, washer based	2	

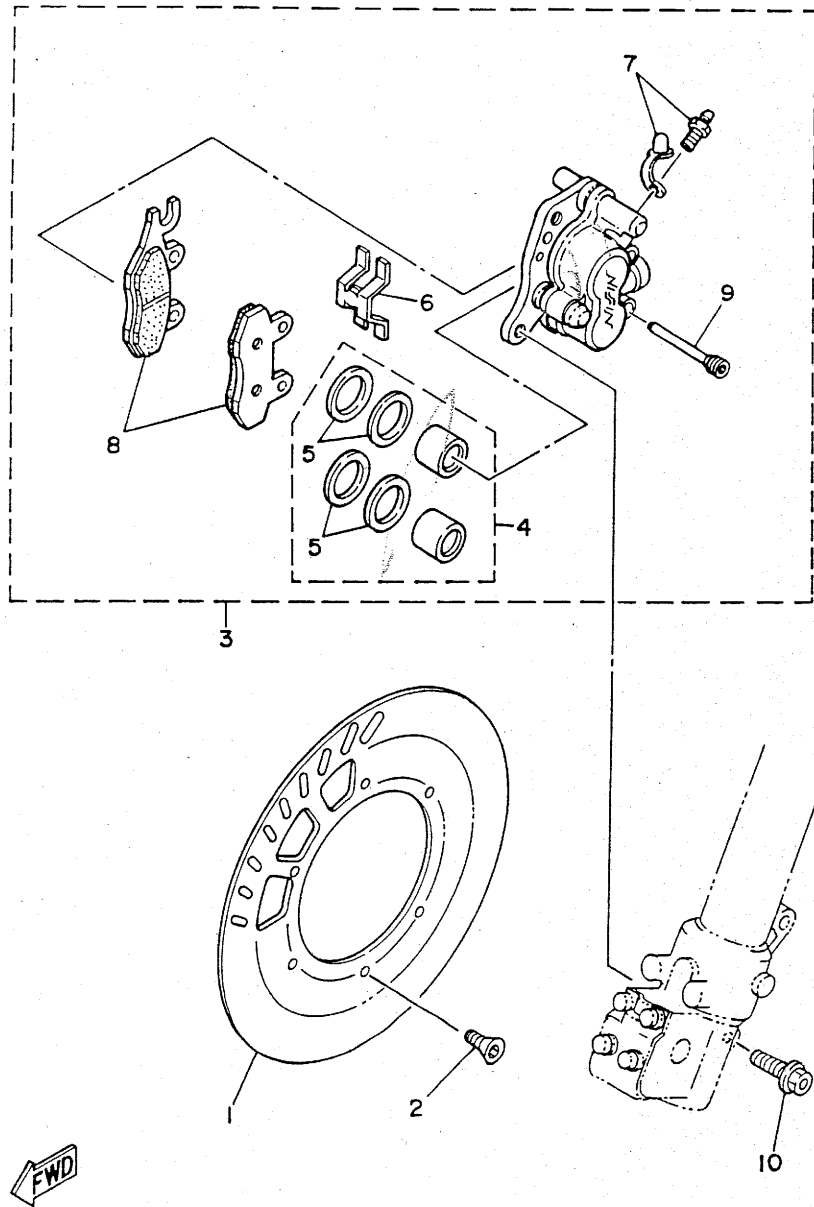
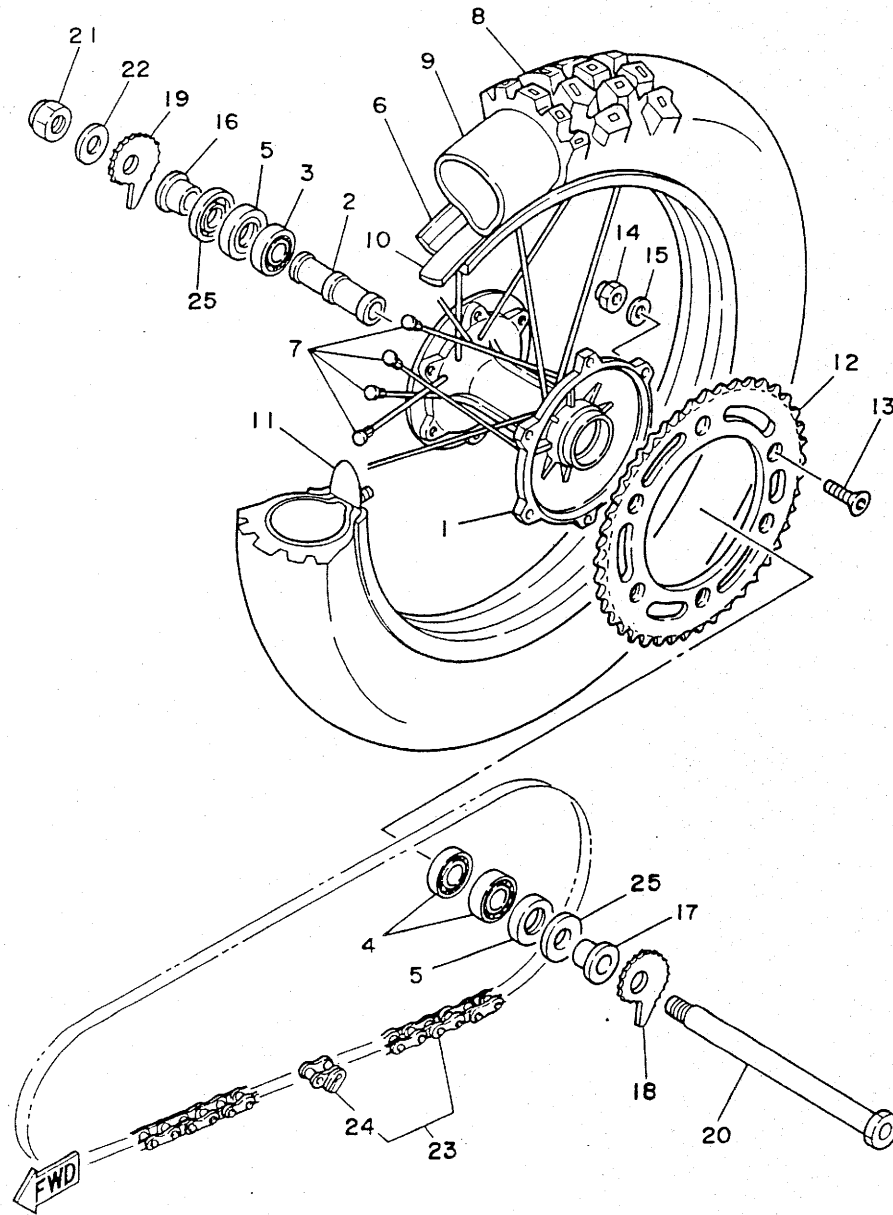


FIG. 27 REAR WHEEL



REF. NO.	PART NO.	DESCRIPTION	Q'TY	REMARKS
1	3SP-25311-00	HUB, rear	1	
2	3JD-25317-01	SPACER, bearing	1	
3	93306-00418	BEARING	1	
4	93306-00438	BEARING	2	
5	93106-28023	OIL SEAL	2	
6	94421-18498	RIM (2.15-18)	1	
7	2VN-25304-00	SPOKE SET, rear	1	
8	110/100 x 18	TIRE	1	
9	130/80 x 18	TUBE	1	
10	94340-18086	BAND, rim (4.00-18)	1	
11	39X-25394-00	SPACER, bead	2	
12	26A-25452-50	SPROCKET, driven (52T)	1	STD
	26A-25444-50	SPROCKET, driven (44T)	1	AP
	26A-25446-50	SPROCKET, driven (46T)	1	AP
	26A-25448-50	SPROCKET, driven (48T)	1	AP
	26A-25450-50	SPROCKET, driven (50T)	1	AP
13	90109-08792	BOLT	6	
14	95611-08100	NUT, u	6	
15	90201-081A6	WASHER, plate	6	
16	90387-203V0	COLLAR	1	
17	90387-200Y5	COLLAR	1	
18	3BN-25388-00	PULLER, chain 1	1	
19	3BN-25389-00	PULLER, chain 2	1	
20	3XP-25381-00	AXLE, wheel	1	
21	90185-18104	NUT, self-locking	1	
22	92901-20600	WASHER	1	
23	94581-08116	CHAIN	1	
24	94681-08011	.JOINT, chain (D.I.D 520V6-FJ)	1	

FIG. 27 REAR WHEEL

REF. NO.	PART NO.	DESCRIPTION	Q'TY	REMARKS
25	4V4-25367-00	COVER, hub dust	2	

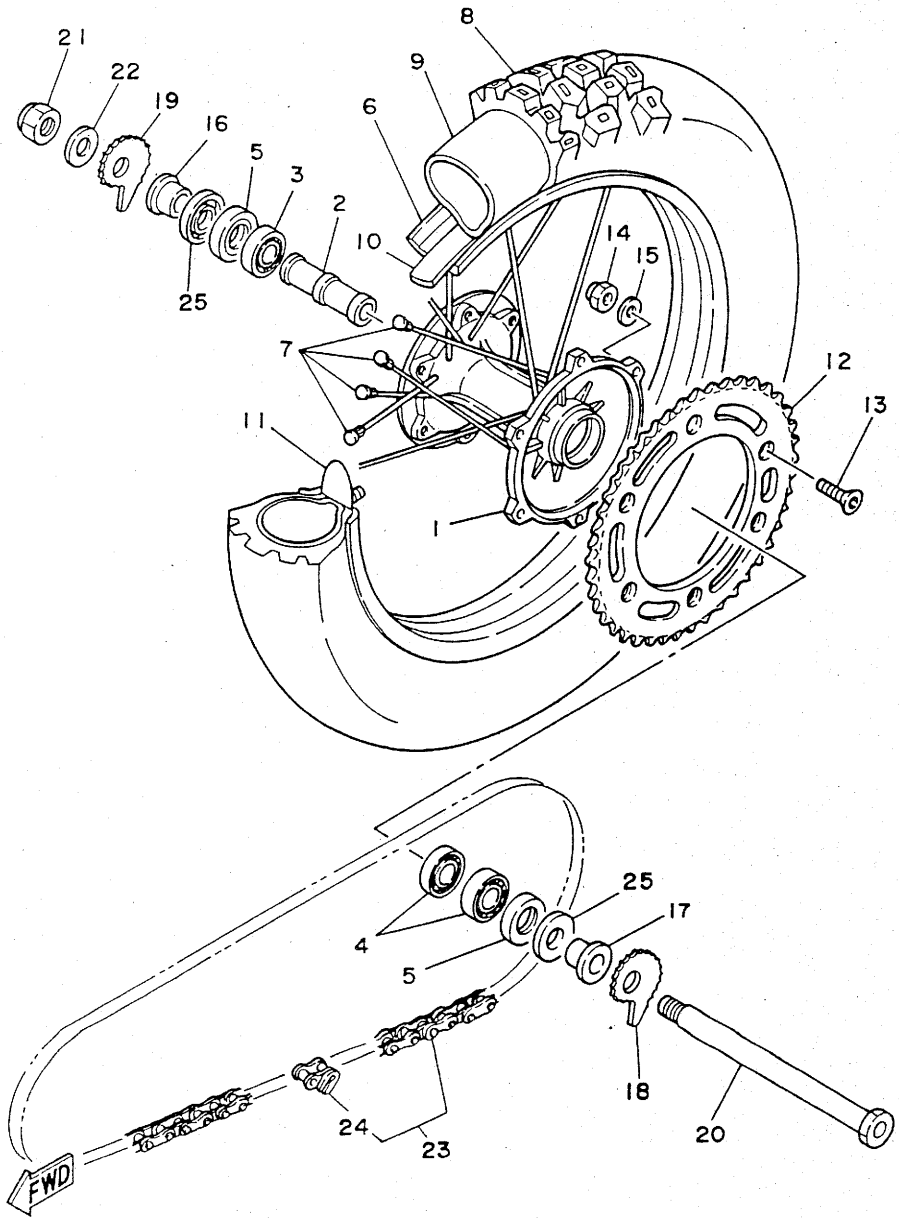
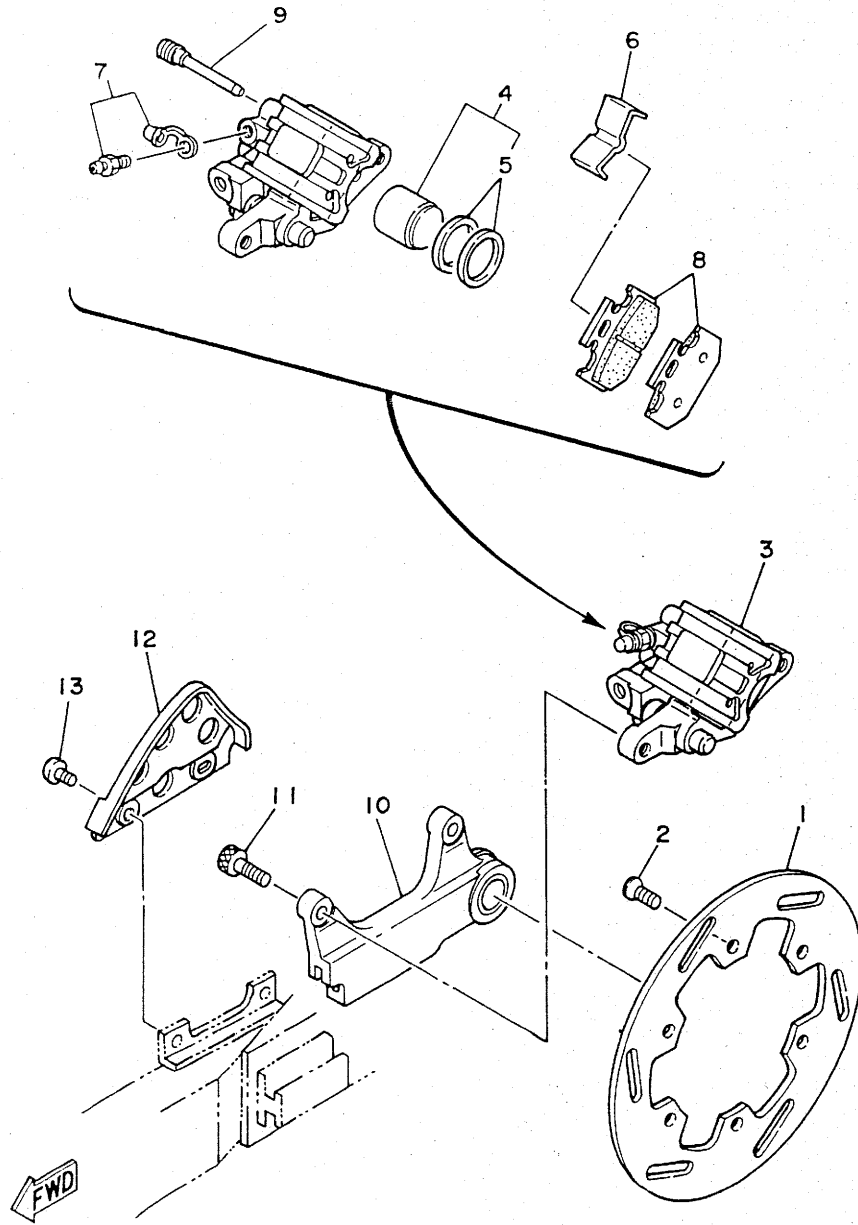


FIG. 28 REAR BRAKE CALIPER



REF. NO.	PART NO.	DESCRIPTION	Q'TY	REMARKS
1	4DA-2582W-00	DISC, rear brake 2	1	
2	90149-06272	SCREW	6	
3	4AA-2580W-00	CALIPER ASSY, rear 2	1	
4	3SP-W0057-50	.PISTON ASSY, caliper	1	
5	3JD-W0047-50	..CALIPER SEAL KIT	1	
6	3SP-25919-51	.SUPPORT, pad	1	
7	1UY-W0048-50	.BLEED SCREW KIT	1	
8	3XP-W0046-00	.BRAKE PAD KIT 2	1	
9	3SP-25924-51	.PIN, pad	2	
10	3XJ-25920-00	SUPT. BRKT. ASSY	1	
11	91311-08025	BOLT	2	
12	3JD-27491-00	PROTECTOR	1	
13	92011-06012	BOLT, button head	2	

FIG. 29 STEERING HANDLE. CABLE

REF. NO.	PART NO.	DESCRIPTION	Q'TY	REMARKS
1	3XJ-26111-00	HANDLEBAR	1	
2	1LX-26241-01	GRIP (LEFT)	1	
3	1LX-26242-01	GRIP (RIGHT)	1	
4	23X-26243-00	TUBE, throttle guide	1	
5	23X-26281-00	CAP, grip upper	1	
6	431-26282-02	CAP, grip lower	1	
7	5X2-2628H-01	CAP, wire	1	
8	98706-04012	SCREW, flat head	2	
9	98506-05016	SCREW, pan head	2	
10	4AA-26311-00	CABLE, throttle 1	1	
11	3XK-26335-00	CABLE, clutch	1	
12	90123-08090	BOLT	1	
13	90179-08401	NUT	1	
14	90464-14117	CLAMP	1	
15	90560-22281	SPACER	1	

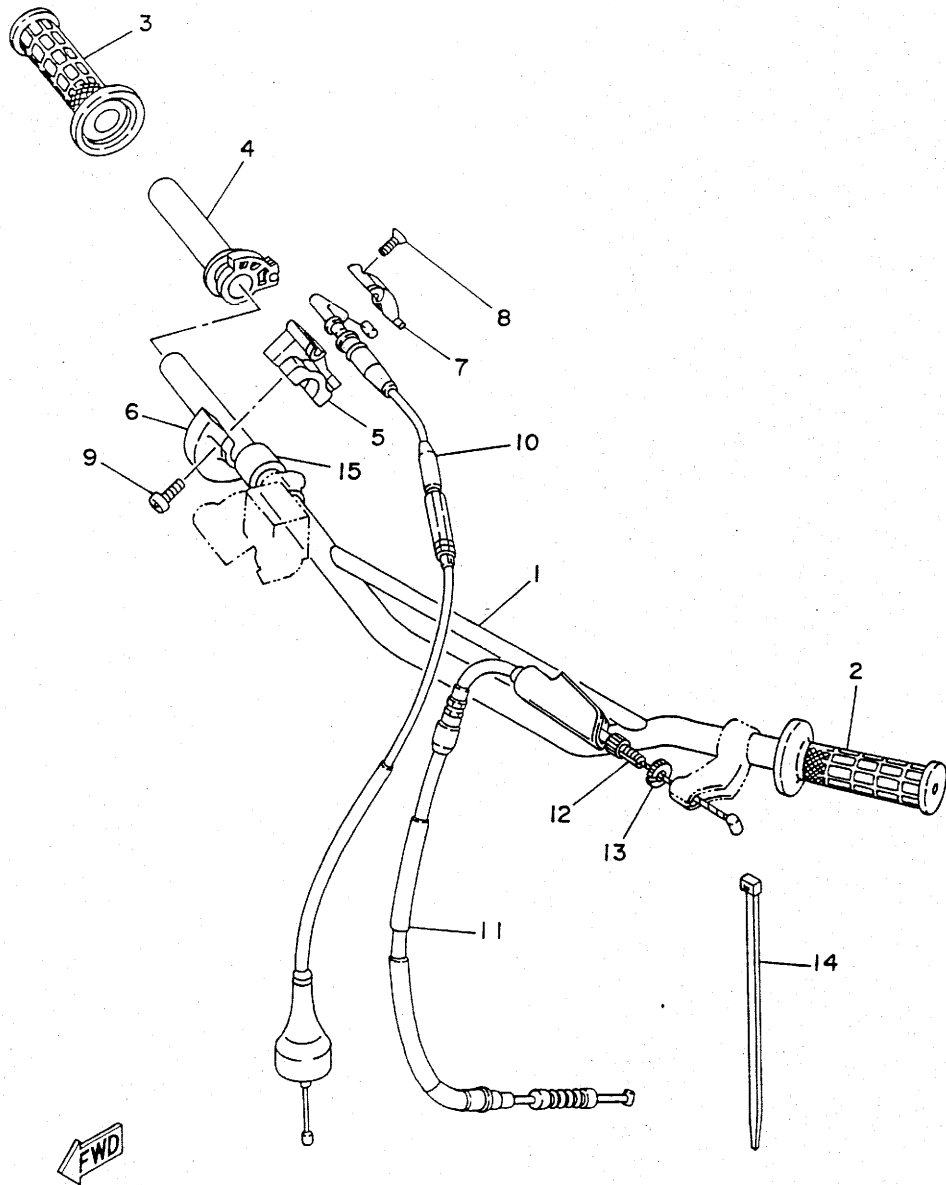
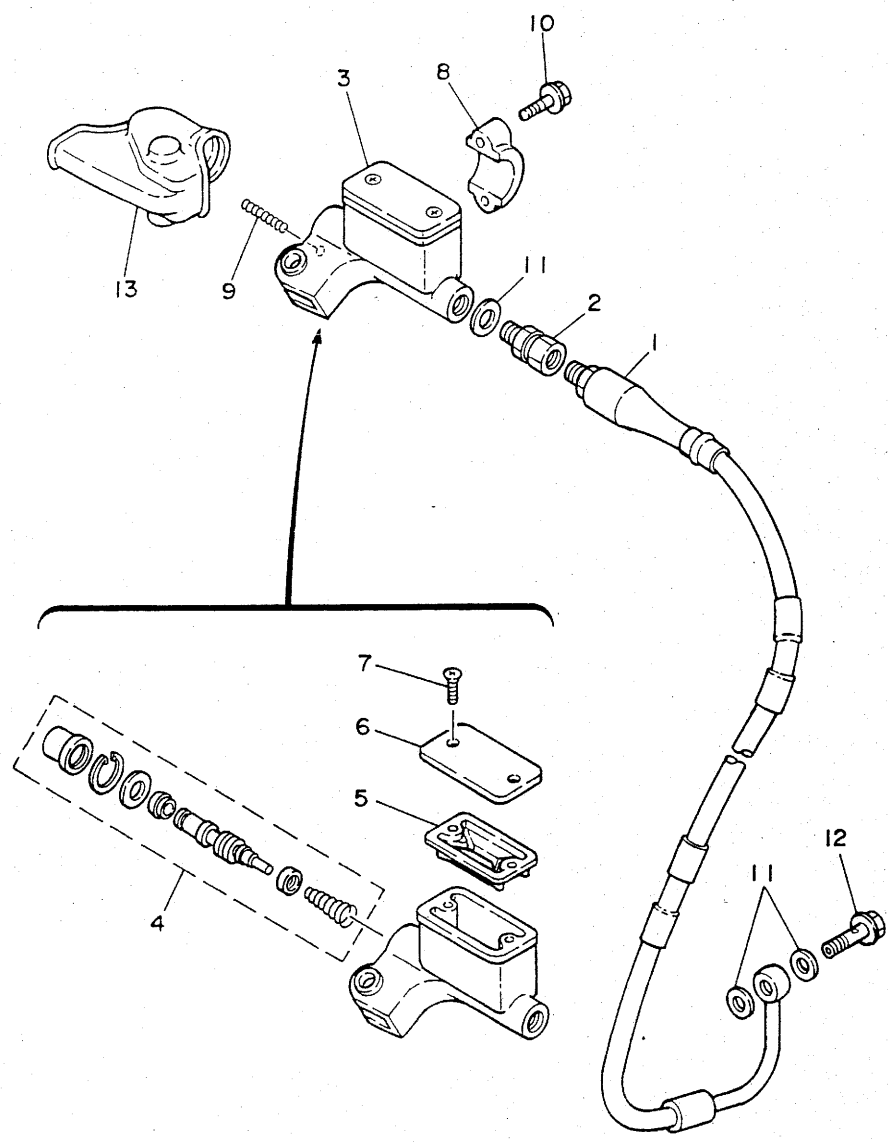


FIG. 30 FRONT MASTER CYLINDER

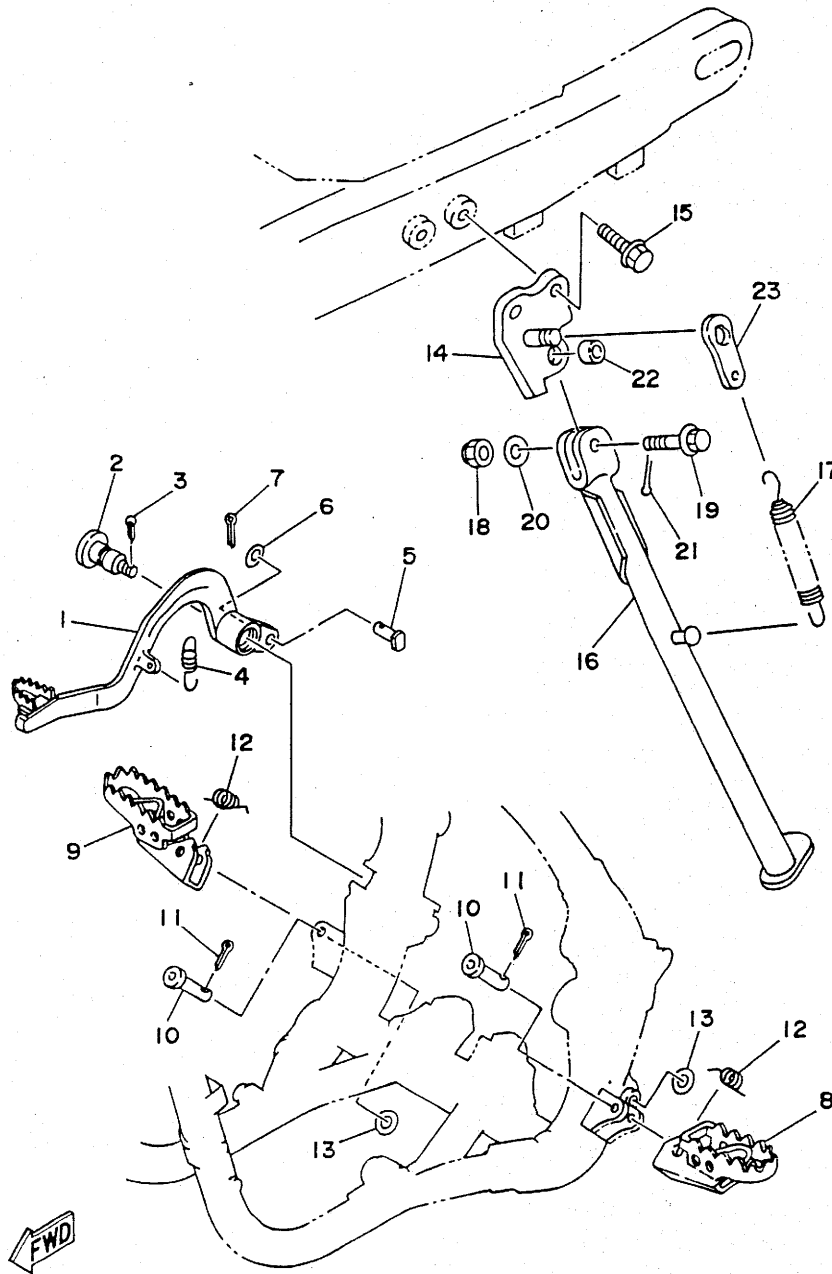


REF. NO.	PART NO.	DESCRIPTION	Q'TY	REMARKS
1	4DA-25872-00	HOSE, brake 1	1	
2	3LC-25885-00	JOINT	1	
3	3SP-25870-00	MASTER CYLINDER SUB ASSY	1	
4	3SP-W0041-00	.CYLINDER KIT, master	1	
5	56A-25854-00	.DIAPHRAGM, reservoir	1	
6	2VN-25852-00	.CAP, reservoir	1	
7	98706-04012	.SCREW, flat head	2	
8	56A-25867-00	BRACKET, master cylinder	1	
9	90501-061G2	SPRING, compression	1	
10	95026-06025	BOLT, flange	2	
11	90201-10118	WASHER, plate	3	
12	90401-10034	BOLT, union	1	
13	56A-26372-01	COVER, handle lever 1	1	

FWD

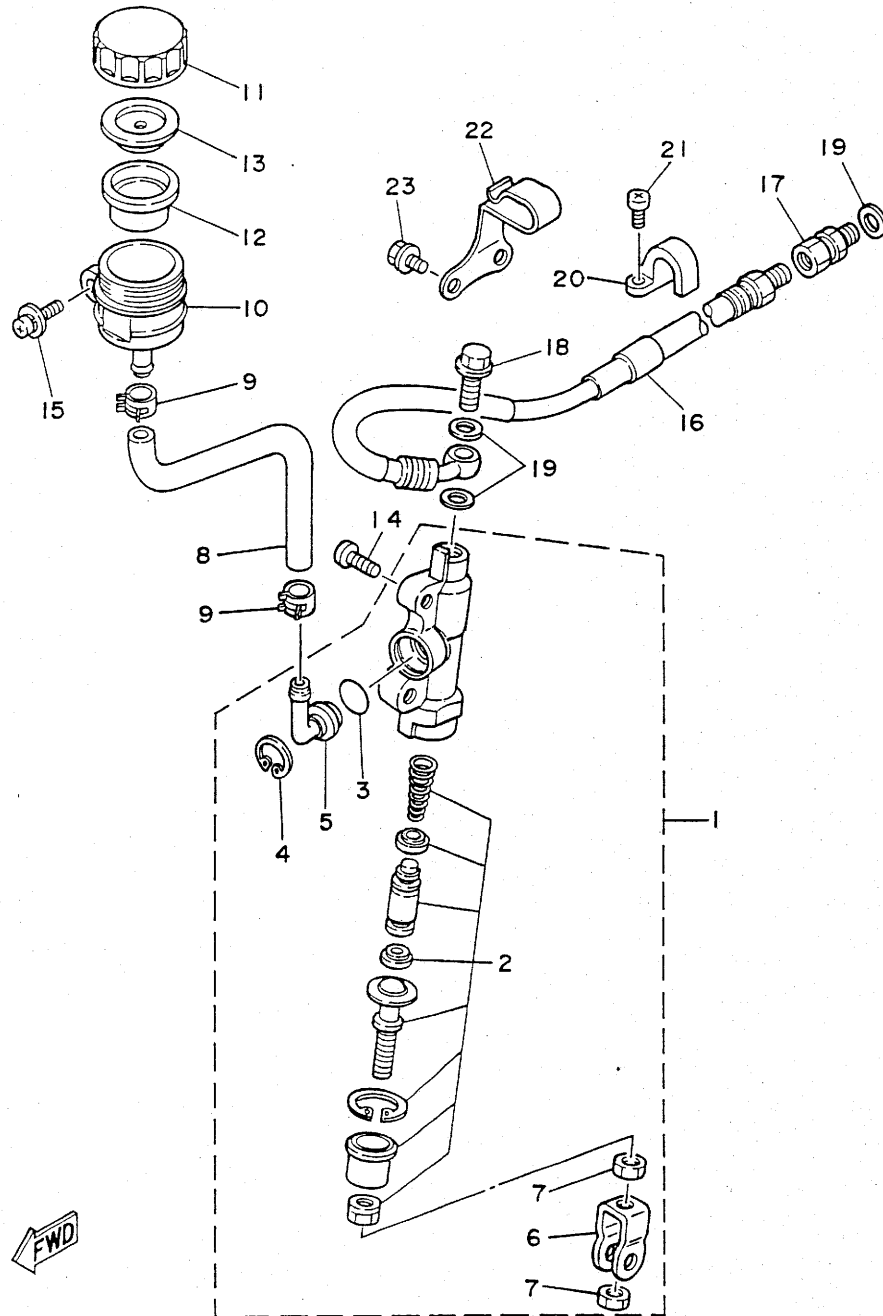


FIG. 31 STAND. FOOTREST



REF. NO.	PART NO.	DESCRIPTION	Q'TY	REMARKS
1	3SP-27200-00	PEDAL, brake	1	
2	4AA-27217-00	BOLT	1	
3	91401-20020	PIN, cotter	1	
4	90506-14410	SPRING, tension	1	
5	90240-08120	PIN, clevis	1	
6	92901-08600	WASHER, plate	1	
7	91401-25020	PIN, cotter	1	
8	4DA-27411-00	FOOTREST 1	1	
9	4DA-27421-00	FOOTREST 2	1	
10	90240-10117	PIN, clevis	2	
11	91401-25020	PIN, cotter	2	
12	90508-28777	SPRING, torsion	2	
13	90201-10119	WASHER, plate	2	
14	4AA-27321-00-T9	BRACKET, side stand	1	COMPETITION SILVER
15	90105-10666	BOLT, washer based	2	
16	4AA-27311-01	STAND, side	1	
17	90507-32059	SPRING, tension	1	
18	90185-10120	NUT, self-locking	1	
19	90105-10549	BOLT, washer based	1	
20	92990-10200	WASHER, plain	1	
21	91401-25020	PIN, cotter	1	
22	90387-133Y9	COLLAR	1	
23	4AA-27263-00	BRACKET 1	1	

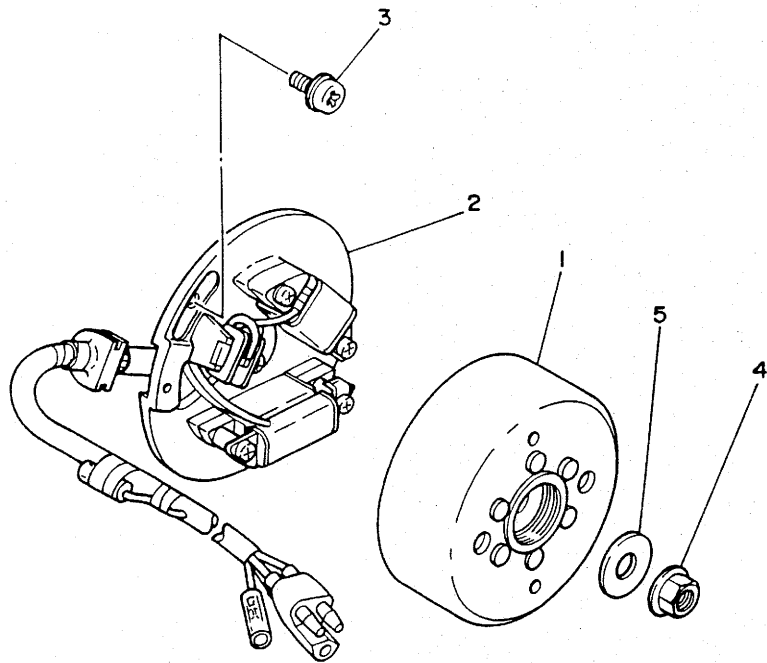
FIG. 32 REAR MASTER CYLINDER



REF. NO.	PART NO.	DESCRIPTION	Q'TY	REMARKS
1	3SP-2583V-00	RR. MASTER CYLINDER ASSY	1	
2	1FK-W0042-50	.CYLINDER KIT, master	1	
3	93210-15620	.O-RING	1	
4	2VN-25866-00	.CIRCLIP	1	
5	2VN-2582A-50	.JOINT	1	
6	3SP-27222-00	.JOINT	1	
7	95303-08600	.NUT	2	
8	3JD-25895-00	HOSE, reservoir	1	
9	90467-11044	CLIP	2	
10	2VN-25894-00	TANK, reservoir	1	
11	3XP-25852-50	CAP, reservoir	1	
12	2VN-25854-00	DIAPHRAGM, reservoir	1	
13	2VN-25855-00	BUSH, diaphragm	1	
14	92013-06016	BOLT	2	
15	90159-06056	SCREW, with washer	1	
16	3SP-25873-00	HOSE, brake 2	1	
17	3LC-25885-00	JOINT	1	
18	90401-10034	BOLT, union	1	
19	90201-10118	WASHER, plate	3	
20	2VM-25876-00	HOLDER, brake hose 2	1	
21	97780-50510	SCREW, tapping	2	
22	90462-12195	CLAMP	1	
23	95023-06008	BOLT	2	

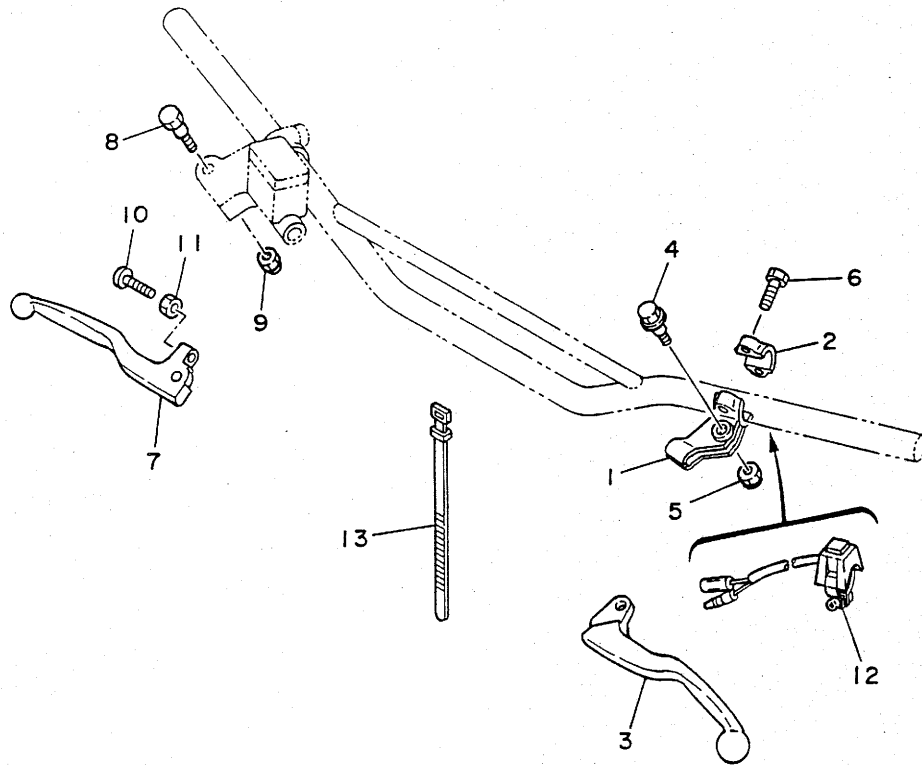
FIG. 33 GENERATOR

REF. NO.	PART NO.	DESCRIPTION	Q'TY	REMARKS
1	3SP-85550-10	ROTOR ASSY	1	
2	3RB-85560-11	BASE ASSY	1	
3	90149-06011	SCREW	2	
4	90179-10394	NUT	1	
5	90201-10774	WASHER, plate	1	



FWD

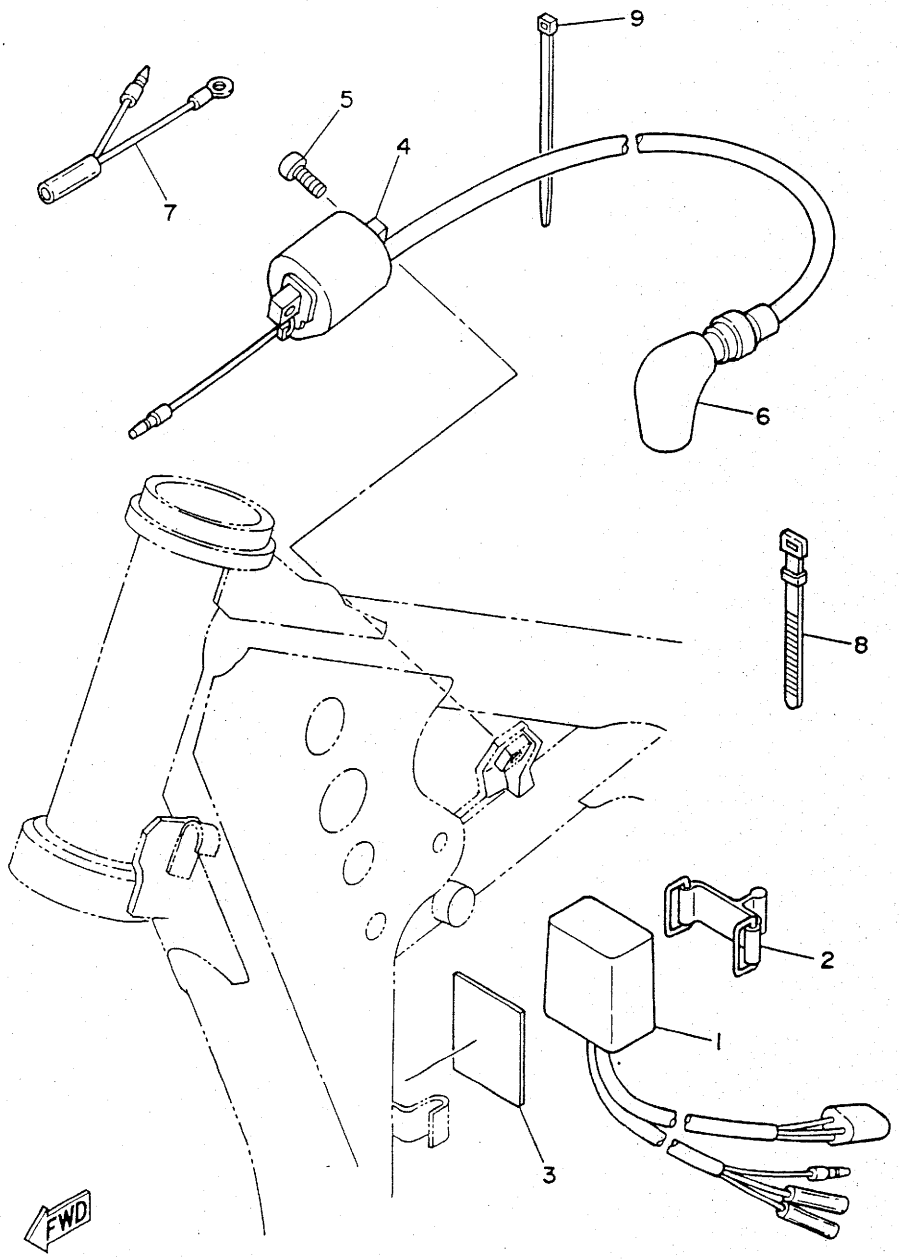
FIG. 34 HANDLE SWITCH. LEVER



REF. NO.	PART NO.	DESCRIPTION	Q'TY	REMARKS
1	38V-82911-00	HOLDER, lever 1	1	
2	38V-82913-00	HOLDER, lever lower 1	1	
3	23X-83912-00	LEVER 1	1	
4	90109-06799	BOLT	1	
5	95616-06100	NUT, u	1	
6	97006-05016	BOLT	2	
7	3SP-83922-00	LEVER 2	1	
8	90109-06577	BOLT	1	
9	95616-06100	NUT, u	1	
10	90149-06153	SCREW	1	
11	90170-06010	NUT	1	
12	23X-83976-00	SWITCH, handle 1	1	
13	437-83936-01	BAND, switch cord	2	

FWD

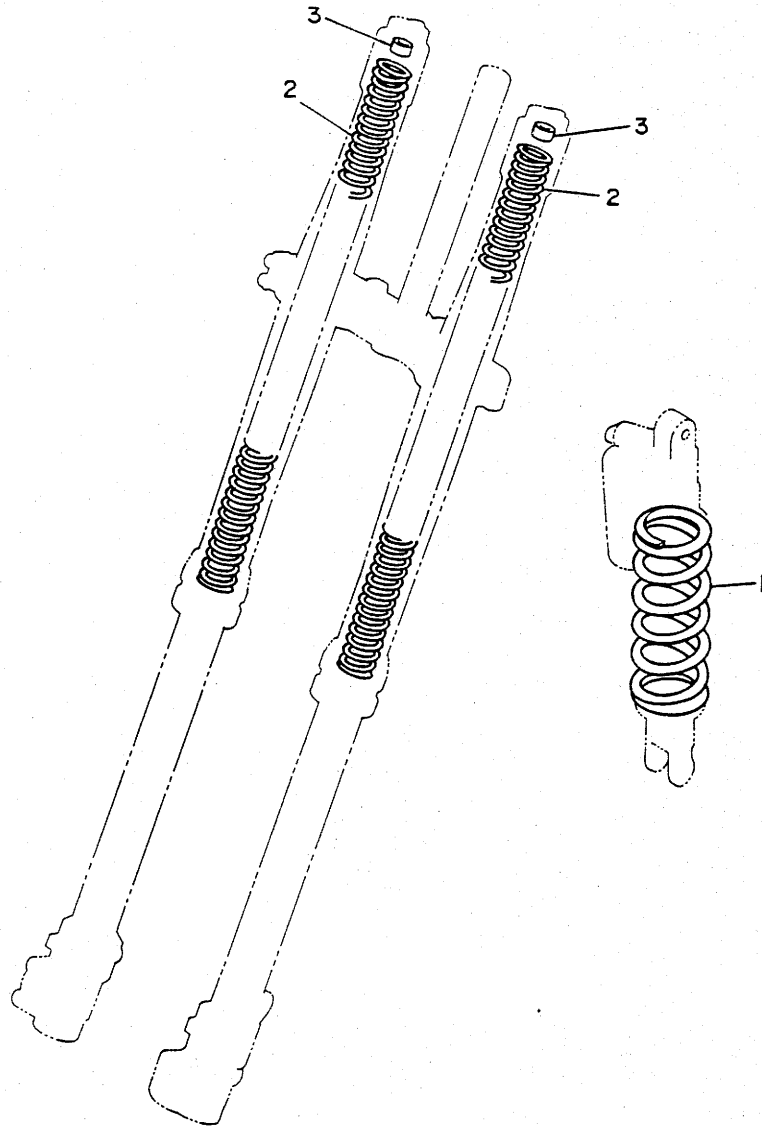
FIG. 35 ELECTRICAL 1



REF. NO.	PART NO.	DESCRIPTION	Q'TY	REMARKS
1	3RB-85540-11	C.D.I. UNIT ASSY	1	
2	5H9-21376-00	BAND, tool	1	
3	3RB-85547-01	DAMPER	1	
4	3SR-82310-10	IGNITION COIL ASSY	1	
5	97021-06016	BOLT	2	
6	2TV-82370-00	PLUG CAP ASSY	1	WITH NOISE SUPPRESSOR
7	5X1-82519-01	WIRE, earth lead	1	
8	25G-83936-01	BAND, switch cord	1	
9	12R-82591-00	BAND	1	

FIG. 36 ALTERNATE (CHASSIS)

REF. NO.	PART NO.	DESCRIPTION	Q'TY	REMARKS
1	3XJ-22212-01	SPRING (K=4.6)	1	AP (SOFT)
	4DA-22212-20	SPRING (K=5.0)	1	AP (HARD)
2	4DA-23141-30	SPRING, front fork (K=0.380)	2	AP (SOFT)
	4DA-23141-50	SPRING, front fork (K=0.400)	2	AP (HARD)
3	3XJ-23364-L0	COLLAR 2	1	UN



FWD